

Errata

Title & Document Type: 83558A Source Module System Manual

Manual Part Number: 83558-90001

Revision Date: May 1990

HP References in this Manual

This manual may contain references to HP or Hewlett-Packard. Please note that Hewlett-Packard's former test and measurement, semiconductor products and chemical analysis businesses are now part of Agilent Technologies. We have made no changes to this manual copy. The HP XXXX referred to in this document is now the Agilent XXXX. For example, model number HP8648A is now model number Agilent 8648A.

About this Manual

We've added this manual to the Agilent website in an effort to help you support your product. This manual provides the best information we could find. It may be incomplete or contain dated information, and the scan quality may not be ideal. If we find a better copy in the future, we will add it to the Agilent website.

Support for Your Product

Agilent no longer sells or supports this product. You will find any other available product information on the Agilent Test & Measurement website:

www.tm.agilent.com

Search for the model number of this product, and the resulting product page will guide you to any available information. Our service centers may be able to perform calibration if no repair parts are needed, but no other support from Agilent is available.

HP 83558A
SOURCE MODULE
75.0 to 110.0 GHz

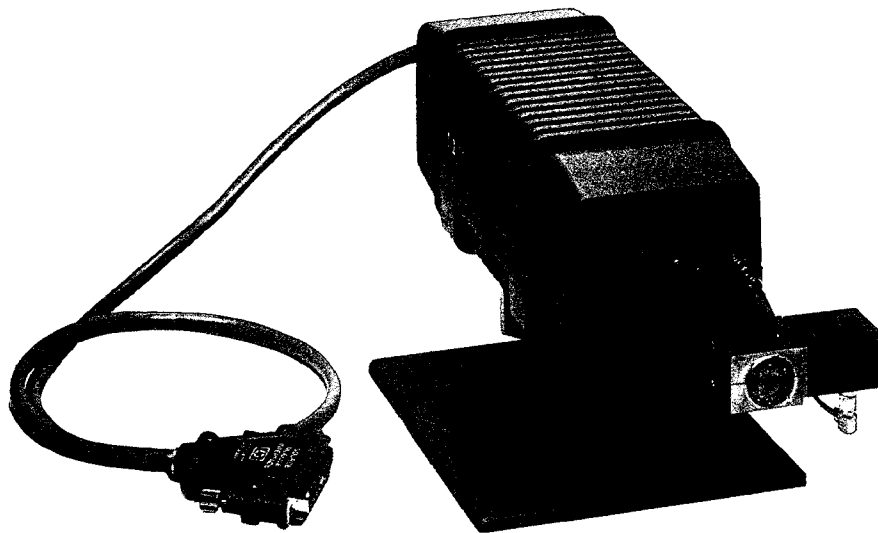

**HEWLETT
PACKARD**

HP 83558A MILLIMETER-WAVE SOURCE MODULE

SERIAL NUMBERS

This manual applies directly to HP 83558A Millimeter-wave source modules having serial number 2948A00101 and higher.

For additional information about serial numbers, refer to INSTRUMENTS COVERED BY MANUAL in System General Information.

©Copyright HEWLETT-PACKARD COMPANY 1990
1400 FOUNTAINGROVE PARKWAY, SANTA ROSA, CA 95403 U.S.A.

MANUAL PART NO. 83558-90001
Microfiche Part Number 83558-90002

Printed: MAY 1990



TABLE OF CONTENTS

SECTION 1. SYSTEM GENERAL INFORMATION

Introduction	1-1
Options	1-1
Description	1-1
Specifications	1-2
Instruments Covered by Manual	1-2
Systems Covered by Manual	1-2
System Descriptions	1-3
System Components Available	1-3
Accessories	1-3
Complete Measurement Systems	1-6
Millimeter-wave Vector Network Analysis	1-6
Millimeter-wave Scalar Network Analysis	1-6
Signal Analysis	1-7
Reference Literature	1-8
Safety Considerations	1-8
General	1-8
Safety Symbols	1-9
Site Preparation	1-9
Space Requirements	1-9
Power Outlets	1-9
Environmental Requirements	1-9
Telephone Considerations	1-10
Initial Inspection	1-10
Receiving Checklist	1-11
Installation	1-11
Introduction	1-11
Coupler/Detector Installation	1-12
System Installation	1-14
Storage and Shipment	1-15
Storage	1-15
Shipment	1-15
Returning for Service	1-15
Manual Changes	1-16

SECTION 2. SOURCE SYSTEM GUIDES

Introduction	2-1
Recommended Test Equipment	2-1
Specifications	2-1
Operation	2-1
Performance Tests	2-1
System Level Troubleshooting	2-2

SECTION 2a. HP 83550A SOURCE SYSTEM GUIDE

Introduction	2a-1
System Description	2a-1
System Specifications	2a-2
Operation	2a-3
Introduction	2a-3
Frequency Control	2a-3
Power Level Control	2a-4
Power Leveling	2a-5
System Leveling	2a-5
External Power Meter Leveling	2a-5
Modulation	2a-6
Frequency Modulation	2a-6
Amplitude Modulation	2a-6
Pulse Modulation	2a-6
Operator's Check	2a-7
Description	2a-7
Equipment	2a-7

Procedure	2a-8
System Performance Tests	2a-11
Introduction	2a-11
Equipment Required	2a-11
Operation Verification	2a-11
Test Record	2a-11
Frequency Characteristics	2a-12
Modulation Characteristics	2a-12
External FM	2a-12
Troubleshooting	2a-14
Specification Failures	2a-14
Error Codes	2a-14

SECTION 2b. HP 83592C/83595C SOURCE SYSTEM GUIDE

Introduction	2b-1
System Description	2b-1
System Specifications	2b-2
Operation	2b-3
Introduction	2b-3
Frequency Control	2b-4
Power Level Control	2b-4
Power Leveling	2b-5
System Leveling	2b-5
External Power Meter Leveling	2b-5
Modulation	2b-6
Frequency Modulation	2b-6
Amplitude Modulation	2b-7
Pulse Modulation	2b-7
Operating Suggestions	2b-8
Operator's Check	2b-9
Description	2b-9
Equipment	2b-9
Procedure	2b-10
System Performance Tests	2b-13
Introduction	2b-13
Equipment Required	2b-13
Operation Verification	2b-13
Test Record	2b-13
Frequency Characteristics	2b-14
Modulation Characteristics	2b-14
External FM	2b-14
Troubleshooting	2b-16
Specification Failures	2b-16

SECTION 2c. HP 8341B (Option 003) SOURCE SYSTEM GUIDE

Introduction	2c-1
System Description	2c-1
System Specifications	2c-2
Operation	2c-3
Introduction	2c-3
Frequency Control	2c-4
Power Level Control	2c-4
Power Leveling	2c-5
System Leveling	2c-5
External Power Meter Leveling	2c-5
Modulation	2c-6
Frequency Modulation	2c-6
Amplitude Modulation	2c-6
Pulse Modulation	2c-7

Operating Suggestions	2c-7
Operator's Check	2c-9
Description	2c-9
Equipment	2c-9
Procedure	2c-10
System Performance Tests	2c-13
Introduction	2c-13
Equipment Required	2c-13
Operation Verification	2c-13
Test Record	2c-13
Frequency Characteristics	2c-14
Troubleshooting	2c-16
Specification Failures	2c-16

SECTION 2d. HP 8673C/D SOURCE SYSTEM GUIDE

Introduction	2d-1
System Description	2d-1
System Specifications	2d-2
Operation	2d-3
Introduction	2d-3
Frequency Control	2d-4
Power Level Control	2d-4
Power Leveling	2d-4
System Leveling	2d-4
External Power Meter Leveling	2d-5
Modulation	2d-5
Frequency Modulation	2d-5
Amplitude Modulation	2d-6
Pulse Modulation	2d-6
Operator's Check	2d-7
Description	2d-7
Equipment	2d-7
Procedure	2d-8
System Performance Tests	2d-11
Introduction	2d-11
Equipment Required	2d-11
Operation Verification	2d-11
Test Record	2d-11
Frequency Characteristics	2d-12
Modulation Characteristics	2d-12
External FM	2d-12
Troubleshooting	2d-14
Specification Failures	2d-14

SECTION 2e. HP 83623A/83624A SOURCE SYSTEM GUIDE

Introduction	2e-1
System Description	2e-1
System Specifications	2e-2
Operation	2e-3
Introduction	2e-3
Frequency Control	2e-4
Power Level Control	2e-4
Power Leveling	2e-4
System Leveling	2e-4
External Power Meter Leveling	2e-4
Modulation	2e-5
Frequency Modulation	2e-5
Amplitude Modulation	2e-5
Pulse Modulation	2e-6

Operator's Check	2e-7
Description	2e-7
Equipment	2e-7
Procedure	2e-8
System Performance Tests	2e-11
Introduction	2e-11
Equipment Required	2e-11
Operation Verification	2e-11
Test Record	2e-11
Frequency Characteristics	2e-12
Troubleshooting	2e-14
Specification Failures	2e-14

SECTION 3. SPECIFICATIONS AND SERVICE

Introduction	3-1
Specifications	3-1
Description	3-3
Equipment Required But Not Supplied	3-3
Recommended Test Equipment	3-3
Mating Connectors	3-4
Preparation for Use	3-4
Source Module Performance Tests	3-5
Introduction	3-5
Equipment Required	3-5
Operation Verification	3-5
Test Record	3-5
Calibration Cycle	3-6
Maximum Leveled Power Test	3-7
Power Level Flatness Test	3-9
Power Level Accuracy Test	3-11
Output SWR Test	3-13
Multiplier Harmonic Test	3-16
Multiplier Harmonic Signals	3-17
Signal Identification	3-19
Measurement Uncertainty	3-19
Other Spurious Signals	3-19
Service	3-21
Introduction	3-21
Safety Considerations	3-21
Service Procedure	3-21
Adjustments	3-21
Theory of Operation	3-22
Introduction	3-22
A2 R-Band Amplifier/Doubler Assembly and Related Biases	3-22
A4 W-Band Amplifier/Doubler Assembly and Related Biases	3-22
A6 Coupler/Detector Assembly and Related Biases	3-23
A5 Interface Assembly	3-23
Power Supplies	3-23
Troubleshooting	3-24
Introduction	3-24
If Your Instrument Fails	3-24
Operational Checks	3-24
HP 83558A Block Diagram	3-25
Replaceable Parts	3-27
Introduction	3-27
Replaceable Parts List	3-27
Ordering Information	3-27

SAFETY CONSIDERATIONS

GENERAL

This product and related documentation must be reviewed for familiarization with safety markings and instructions before operation. This product has been designed and tested in accordance with international standards.

SAFETY SYMBOLS



Instruction manual symbol: the product will be marked with this symbol when it is necessary for the user to refer to the instruction manual (refer to Table of Contents).



Indicates hazardous voltages.



Indicates earth (ground) terminal.

WARNING

The WARNING sign denotes a hazard. It calls attention to a procedure, practice, or the like, which, if not correctly performed or adhered to, could result in personal injury. Do not proceed beyond a WARNING sign until the indicated conditions are fully understood and met.



The CAUTION sign denotes a hazard. It calls attention to an operating procedure, practice, or the like, which, if not correctly performed or adhered to, could result in damage to or destruction of part or all of the product. Do not proceed beyond a CAUTION sign until the indicated conditions are fully understood and met.

BEFORE APPLYING POWER

Verify that the product is configured to match the available main power source per the input power configuration instructions provided in this manual.

If this product is to be energized via an auto-transformer make sure the common terminal is connected to the neutral (grounded side of the mains supply).

SERVICING

WARNING

Any servicing, adjustment, maintenance, or repair of this product must be performed only by qualified personnel.

Adjustments described in this manual may be performed with power supplied to the product while protective covers are removed. Energy available at many points may, if contacted, result in personal injury.

Capacitors inside this product may still be charged even when disconnected from their power source.

To avoid a fire hazard, only fuses with the required current rating and of the specified type (normal blow, time delay, etc.) are to be used for replacement.

System General Information

TABLE of CONTENTS

SYSTEM GENERAL INFORMATION

- Introduction**
- Options**
- Description**
- Specifications**
- Instruments Covered by Manual**
- Systems Covered By Manual**
- System Descriptions**
- System Components Available**
- Accessories**
- Complete Measurement Systems**
 - Millimeter-wave Vector Network Analysis**
 - Millimeter-wave Scalar Network Analysis**
 - Signal Analysis**
- Safety Considerations**
 - General**
 - Safety Symbols**
- Site Preparation**
 - Space Requirements**
 - Power Outlets**
 - Environmental Requirements**
 - Telephone Consideration**
 - Initial Inspection**
 - Receiving Checklist**
- Installation**
 - Introduction**
 - Coupler/Detector Installation**
 - System Installation**
- Storage and Shipment**
 - Storage**
 - Shipment**
 - Returning for Service**
- Ordering Manuals**

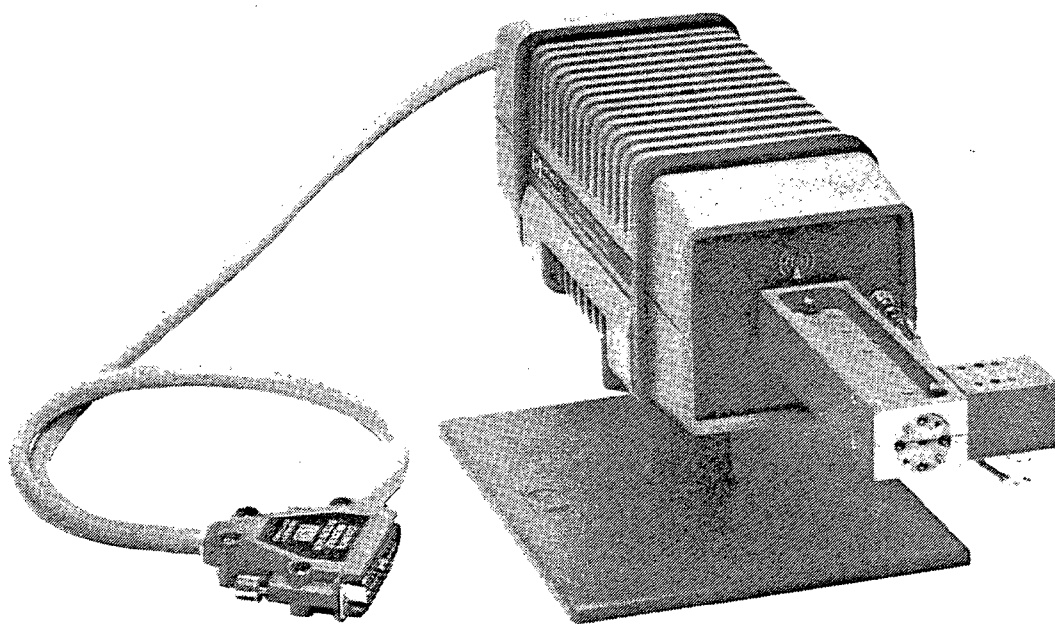

Figure 1-1. HP 83558A Millimeter-wave Source Module

Section 1. System General Information

INTRODUCTION

This manual contains operating and service information for the HP 83558A W-band millimeter-wave source module, shown in Figure 1-1.

Because the HP 83558A source module requires the use of an external signal source to operate, it is necessary to discuss other HP instruments that are compatible with the source module. This manual discusses the operation of these instruments as they affect the use of the source module. For detailed instructions on any of these compatible instruments, refer to the individual instrument's operating and service manual.

This manual is divided into three major headings which provide the following information:

SYSTEM GENERAL INFORMATION provides a brief description of the systems covered by this manual, safety considerations, site preparation, system installation, accessories and operating supplies available. All of the information in this portion of the manual applies to overall maintenance of the W-band source module systems.

SOURCE SYSTEM GUIDES contains the external signal source configurations and the recommended equipment list. This portion is further divided into different source guides. Each source guide contains: connection diagrams, external signal source driven specifications, operating information, performance tests, and system level troubleshooting.

SOURCE MODULE SPECIFICATIONS AND SERVICE provides information that is source module specific, such as the description, specifications, equipment required but not supplied, performance tests and service.

OPTIONS

Option 001. Ordering this option deletes the leveling coupler and detector from the source module.

Option 910. Ordering this option provides an additional operating and service manual for a total of two manuals.

Option W30. Ordering this option adds an additional two years of return to HP Service, for a total of three years. This option is available at the time of sale only.

DESCRIPTION

The HP 83558A millimeter-wave source module is a frequency multiplier that provides a means of obtaining leveled high power, high quality signals covering the waveguide band of 75 to 110 GHz (W-band).

SPECIFICATIONS

The HP 83558A source module specifications are divided into two categories:

- External signal source dependent specifications (system specifications).
- Source module specifications independent of signal source.

External signal source dependent specifications are found in each of the source system guides. Refer to the source system guide that describes the source system you are using.

INSTRUMENTS COVERED BY MANUAL

This manual applies specifically to HP 83558A millimeter-wave source modules. A serial number label is attached to the rear panel of the HP 83558A. Figure 1-2 shows a typical serial number label. The serial number is in two parts. The first four digits followed by a letter comprise the serial number prefix; the last five digits form the sequential suffix that is unique to each instrument. The content of this manual applies directly to instruments having the same serial number prefix as listed on the title page of this manual under SERIAL NUMBER.

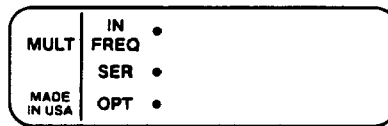

Figure 1-2. Typical Serial Number Label

SYSTEMS COVERED BY MANUAL

Different millimeter-wave (mm-wave) source systems are detailed in this manual under the major heading SOURCE SYSTEM GUIDES. Refer to the source system guide that describes the source system you are using for specific serial number prefix information.

SYSTEM DESCRIPTIONS

The W-band millimeter-wave source system consists of an HP 83558A and a microwave source driver (external signal source) that delivers a minimum of +17 dBm of output power to the RF cable input of the source module at frequencies between 12.5 and 18.33 GHz. Refer to Figure 1-3 for a block diagram of the different configurations.

A source driver can consist of any of the HP models listed in block A together with the HP 8349B, block B. The HP 8349B provides the block A microwave sources with the power amplification, and in some cases the source module interface, needed to drive the HP 83558A.

Other mm-wave source system configurations are shown in block C, directly driving the HP 83558A. These are high powered sources with the source module interface designed into the instrument.

SYSTEM COMPONENTS AVAILABLE

A complete W-band mm-wave measurement system is composed of several instruments and accessories called system components. Refer to Table 1-1 for a list of compatible instruments.

ACCESSORIES

Refer to Table 1-2 for a list of compatible accessories.

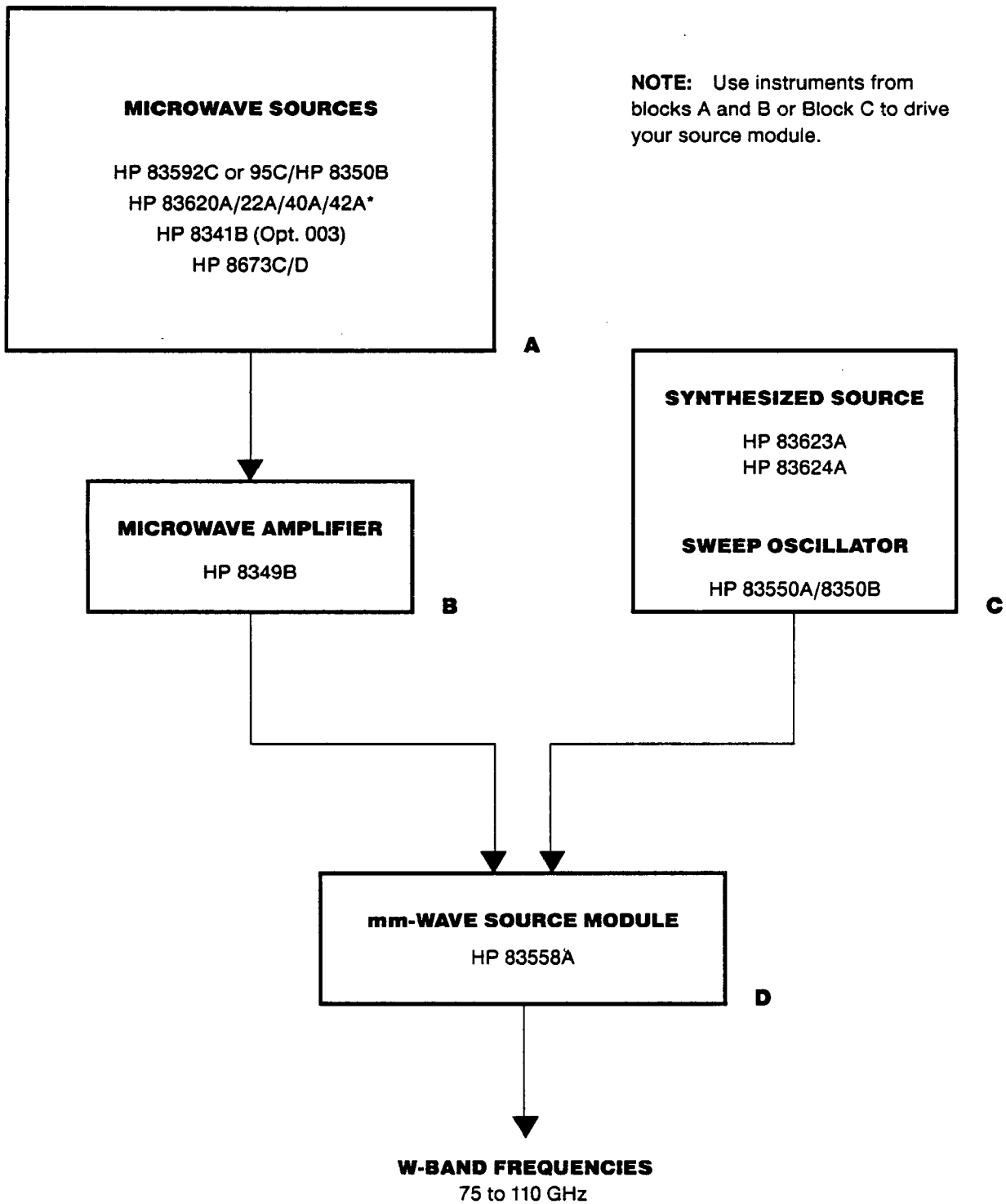

*Refer to the HP 83623A/24A Source System Guide for configuration information.

Figure 1-3. HP 83558A Source Module Configurations

Table 1-1. Compatible Source System Instruments (Accessories listed are required for mm-wave applications)

Instrument	Frequency Range (GHz)	Model
SCALAR NETWORK ANALYZER	75.0 to 110.0	HP 8757A/C/E with HP 85025C Detector Adapter or HP 11664C Detector Adapter
SPECTRUM ANALYZERS	75.0 to 110.0	HP 8566B with HP 11975A Amplifier and HP 11970W Mixer
	75.0 to 110.0	HP 71300A with HP 11970W Mixer
	75.0 to 110.0	HP 8569B with HP 11975A Amplifier and HP 11970W Mixer
	75.0 to 110.0	HP 8569B Option 003 with HP 11970W Mixer
VECTOR NETWORK ANALYZER	75.0 to 110.0	HP 8510B with HP W11643A Test Set Kit and HP W11644A Calibration Kit and HP 85100A LO/IF Interface Kit
POWER METERS	75.0 to 110.0	Anritsu ML83A with Anritsu MP81B Power Sensor

Table 1-2. Compatible Source System Accessories

Frequency Range (GHz)	Model
*	HP 85025C Detector Adapter
*	HP 11664C Detector Adapter
75.0 to 110.0	HP W752C/D Directional Coupler (10, 20 dB)
75.0 to 110.0	HP W910C Load
75.0 to 110.0	HP 11970W Harmonic Mixer
*	HP 11548A Waveguide Holder
*	HP 11540A Waveguide Stand
75.0 to 110.0	HP W898A E-H Plane Twist
75.0 to 110.0	HP W896B Straight Section
75.0 to 110.0	HP W365A Waveguide Isolator
75.0 to 110.0	HP W373D/G Fixed Attenuator (20, 50 dB)
75.0 to 110.0	HP W894 Waveguide Mismatch

* not frequency dependent

COMPLETE MEASUREMENT SYSTEMS

There are several Hewlett-Packard instruments that can be used as mm-wave receivers. Such receivers include the HP 8510 network analyzer, HP 8757 scalar network analyzer, and the HP 71000 Series spectrum analyzer.

Millimeter-wave Vector Network Analysis

The HP 8510 network analyzer can be configured to make high-speed, wide dynamic range vector measurements at millimeter-wave frequencies. Figure 1-4 shows a simplified block diagram for a generic system, applicable to all waveguide bands.

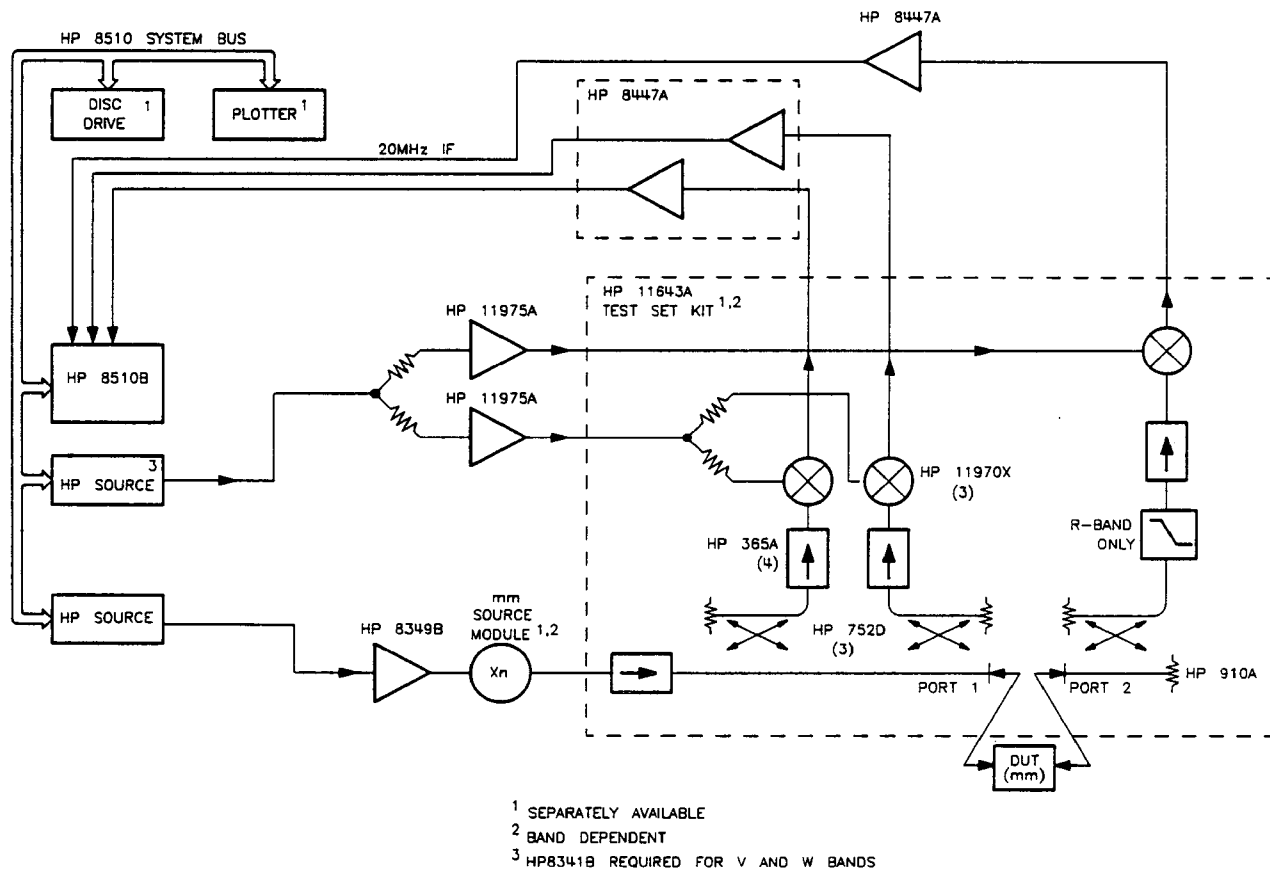

Figure 1-4. Simplified Block Diagram of a Millimeter-wave Vector Network Analyzer System

Millimeter-wave Scalar Network Analysis

HP millimeter-wave source systems can be used for broadband scalar measurements utilizing the HP 8757 scalar network analyzers. Figure 1-5 shows a typical transmission and reflection measurement system.

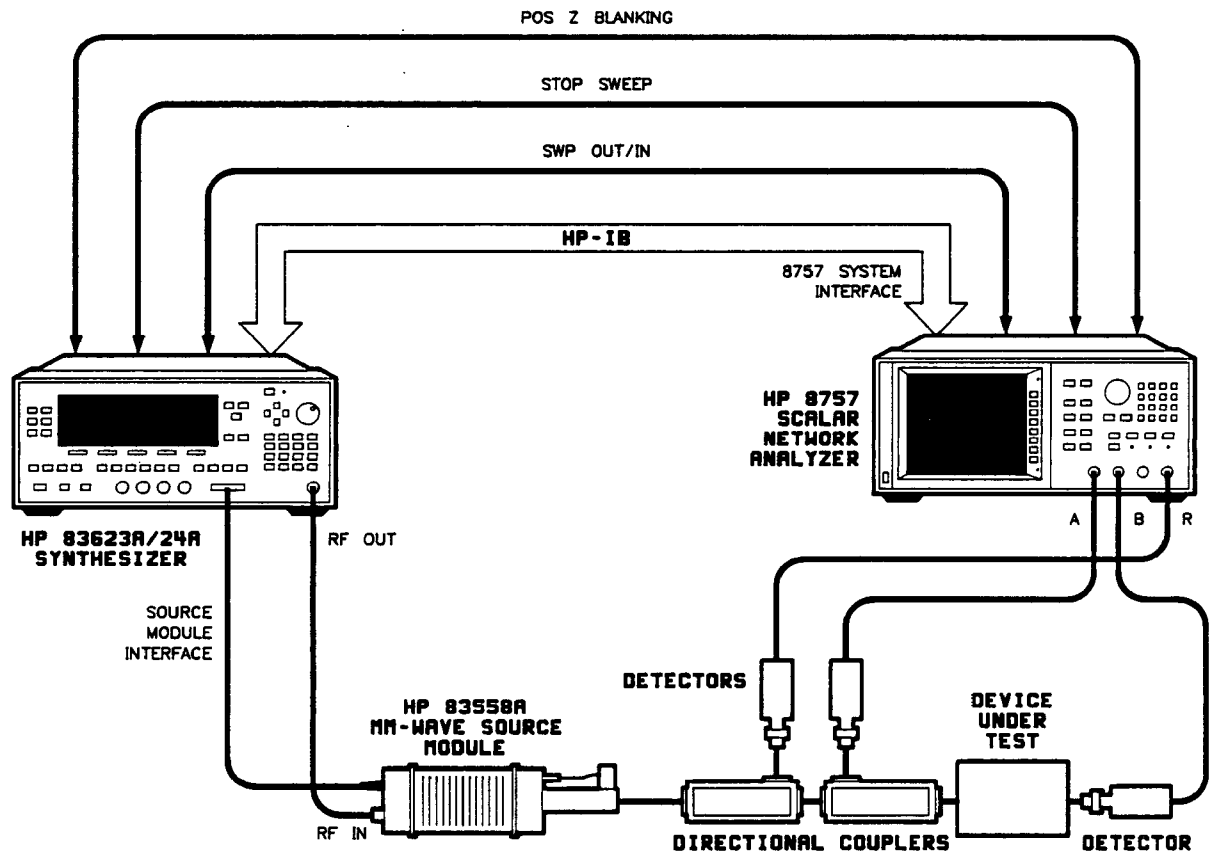

Figure 1-5. Transmission and Reflection Millimeter-wave Measurement System

Signal Analysis

Signal analysis measurements can be made using the HP 11970 Series waveguide harmonic mixers for the HP 8566A/B or the 8569A/B spectrum analyzers, or the HP 71000 Series modular spectrum analyzer to cover waveguide bands from 18 to 110 GHz.

Reference Literature

Data Sheet	<i>HP 8510 network analyzer</i>
HP Product Note 8510-12	<i>Millimeter-wave Measurements Using the HP 8510B Network Analyzer</i>
Data Sheet	<i>HP 8757 scalar network analyzer</i>
Data Sheet	<i>HP 11664C waveguide detector</i>
HP Product Note 8756-2	<i>Using the HP 11664C Detector Adapter to Make Millimeter-wave Scalar Measurements</i>
HP Product Note 8757-2	<i>Millimeter-wave Measurements, V and W Band</i>
Data Sheet	<i>HP 71000 Series modular spectrum analyzer</i>
Data Sheet	<i>HP 8566B spectrum analyzer</i>
HP Product Note 8569B-1	<i>Extending the HP 8569B Spectrum Analyzer Above 22 GHz with External Mixers</i>
HP Product Note 8566A-1	<i>Using the HP 8566A Spectrum Analyzer for Signal Analysis Above 22 GHz with External Mixers</i>
HP Product Note 8566A-2	<i>Extending the HP 8566A Spectrum Analyzer Above 22 GHz with External Mixers</i>
HP Operating Note	<i>Operating Guide for the HP 83550 Series Millimeter-wave Source Modules</i>

SAFETY CONSIDERATIONS

General

Each instrument has been manufactured and tested in accordance with international safety standards. Before operating any instrument, review all documentation to familiarize yourself with safety markings and instructions. For a listing of safety considerations and symbols used in each system component, refer to the individual system component's operating and service manual.

Safety Symbols

A complete listing of the safety symbols used in this manual is given on the page preceding the main table of contents.

WARNING

This equipment is capable of radiating millimeter-wave energy from the end of unterminated waveguide. Do not look directly into the open end of any waveguide when it is connected to a source of millimeter-wave energy.

Take precautions consistent with ANSI C95.1 - 1982, a study performed by the American National Standards Institute that sets limits for human exposure to microwave and millimeter-wave energy. Copies of this publications are available from:

**American National Standards Institute
1430 Broadway
New York, NY 10018**

SITE PREPARATION

It is the customer's responsibility to select and prepare a site suitable for the mm-wave source system. This includes space, power, and environmental requirements.

Space Requirements

A table must be provided to support the source module and a source driver. The table should be at least 1.8 metres (6 ft) long, 0.9 metres (3 ft) wide and able to support 136 kg (300 lbs). A table with a power distribution strip along the back edge is preferred.

Power Outlets

One power outlet for each instrument in your system is required plus an additional two to three outlets for service. The power line should be capable of providing uninterrupted current. Avoid connecting the mm-wave source system to power lines serving equipment that will disturb the line voltage (e.g. air conditioning equipment, electrical welders, copying machines, large motors, etc.). Refer to the individual instrument manuals for power consumption ratings. Add each rating to figure the total power consumption of the system.

Environmental Requirements

For optimum results, operate the source module within the following limits:

Temperature	+25°C, ±5°C (+77°F, ±9°F)
Humidity	Less than 95%, non-condensing

Operation outside these limits is possible with a chance of performance degradation and a higher risk of failure.

Telephone Considerations

A telephone near the mm-wave source system is recommended, especially if on-site service is desired.

INITIAL INSPECTION

Inspect the shipping container for damage. If it is damaged, keep it until you have checked the contents for completeness.

If the shipping container is damaged, perform the performance tests outlined in this manual. If the source module fails the performance tests, or is damaged or defective, keep the shipping materials and notify both the carrier and the nearest Hewlett-Packard office. Hewlett-Packard will arrange for repair or replacement of the source module without waiting for a settlement from the shipping company.

NOTE: If you already own instruments that will be used in a mm-wave source system, verify the operation and/or calibration before integrating them into the system. Certain instruments require modification before they can be used in a mm-wave source system. Refer to the appropriate source system guide for details.

Site Preparation Checklist W-Band Millimeter-Wave Source System

Check each item off as it is completed.	
All Components at Installation Site	<input type="checkbox"/>
System Table	
Support: 135 kg (300 lb)	
Size: 1.8 m (6 ft) x 0.9 m (3 ft)	<input type="checkbox"/>
Power Outlets	
System: minimum 2	
Service: 3	<input type="checkbox"/>
Temperature	
+25 ± 5°C (+77 ± 9°F)	<input type="checkbox"/>
Humidity	
Less than 95%, non-condensing	<input type="checkbox"/>
Telephone	
(useful for on-site service)	<input type="checkbox"/>
Inventory System Components	<input type="checkbox"/>
Perform Incoming Inspection/Calibration	<input type="checkbox"/>
Verify Calibration of Instruments	
(instruments already owned)	<input type="checkbox"/>

Receiving Checklist

Verify that you have received the following items with your source module.

Item	HP Part/Model Number
Source Module	HP 83558A
Coupler/Detector Assembly (standard instruments only)	Part of HP 83558A
Source Module Stand and Cradle Assembly	83556-60010
RF Cable	5061-5359
Synthesizer Cable Interface (for use with HP 8341B Opt. 003)	5061-5391
Allen Driver (standard instruments only)	8710-1539
Operating and Service Manual	83558-90001

INSTALLATION

IntroductionThis section provides instructions for attaching the coupler/detector assembly to the source module, and very general mm-wave source system installation instructions. For specific information on any instrument refer to the individual operating and service manual.

Power Requirements. Most of the instruments obtain power through their own line voltage cord. The two exceptions are:

- The RF plug-in (when applicable), which receives power from the HP 8350 sweep oscillator mainframe.
- The source module, which receives power from the source or the HP 8349B.

CAUTION

To prevent instrument damage, make the correct line voltage and fuse selection for each system component prior to connecting line power to the system.

Line Voltage and Fuse Selection. Each system component must be set to operate with the available AC line voltage, and have the correct line fuse installed. Because system component fuse values for different line voltage settings are not identical, verify that the proper voltage range and corresponding fuse are selected. Line voltage ranges and fuse ratings for system components are given in Section 1 of each component manual, and are often specified on the instrument rear panel. Use the following procedure to determine the correct line voltage setting and fuse value (if necessary):

1. Determine the available line voltage.
2. Refer to the installation section of each instrument manual. Match the correct line voltage and fuse as specified in the manual to the determined AC line voltage. If the measured AC voltage does not fall within the acceptable limits for any range, an auto transformer must be used between the power source and the mm-wave source system.

3. Change the line voltage selector according to the instructions in the installation section of each instrument manual.
4. Insert the proper value fuse for the line voltage range selected.

Power Cables. Each instrument in this mm-wave source system is equipped with a three-wire power cable, in accordance with international safety standards. The cable grounds the instrument system when the cable is connected to an appropriate power line outlet. Table 1-3 shows the plug styles available on power cables supplied with HP instruments. The HP part numbers given for the plugs are the part numbers for complete power cables. The type of power cable/plug shipped with the instrument depends on the country of destination.

System Connections. System connections are discussed in the Source System Guides. Refer to the guide that details the source driver you are using.

Mating Connectors. Refer to the individual instrument's installation section for the type of connector(s) that can be mated with the instrument.

Coupler/Detector Installation



Beware of damage from electro-static discharge (ESD). The coupler/detector assembly and the circuits in the source module are extremely sensitive to electrostatic discharge. Use a grounded wrist strap when you handle these devices.

The coupler/detector assembly is shipped in the same container as the source module but is not attached to the source module. Therefore, you must attach the coupler/detector assembly to the source module upon receipt. Follow the procedure below to do this.

1. Protect yourself from electrostatic discharge (ESD) then remove the coupler/detector assembly and the source module from their packaging.
2. Align the coupler/detector assembly with the source module as shown in Figure 1-6.

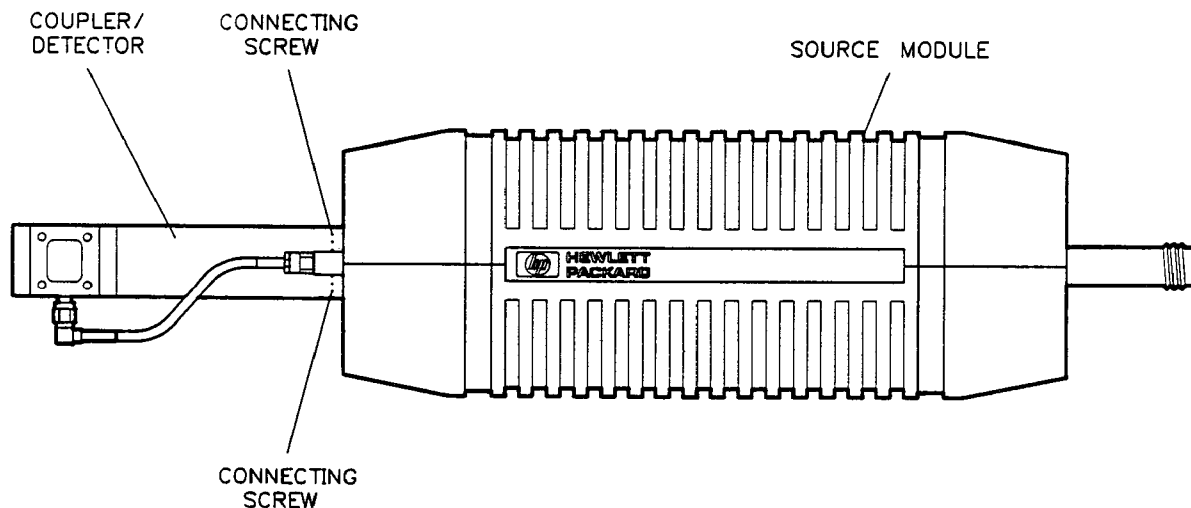

Figure 1-6. Alignment of the Coupler/Detector and Source Module

3. Using an allen driver, tighten the two screws in the coupler at the junction of the coupler and source module.
4. Connect the flexible cable from the detector to the SMC connector on the front panel of the source module.

The coupler/detector assembly installation procedure is complete; the unit should operate as specified.



NOTE: Each coupler/detector assembly is matched to a source module at the factory. The label on the coupler/detector references the serial number of the source module it is matched to and must be used with this source module only. Operation of the source module without the coupler/detector assembly attached is possible, however, the output power of the source module will be unlevelled.

System Installation

Refer to the SITE PREPARATION CHECKLIST earlier in this section before continuing with the system installation.

1. Place the source at least six inches back from the front edge of the table (install the plug-in if required).
2. Place the source module in its cradle stand. Secure the cradle stand to the source module.
3. Check the voltage/fuse selection of the source.
4. Check the power cables.
5. Refer to the appropriate source system guide for specific source connection diagrams.

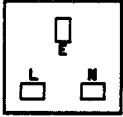
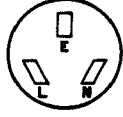
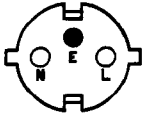
Table 1-3. AC Power Cables Available

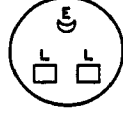
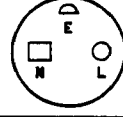
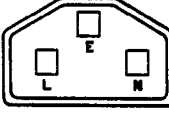
Plug Type ¹	Cable HP Part Number ²	Plug Description ²	Cable Length (inches)	Cable Color	For Use in Country
250V 	8120-1351 8120-1703	Straight BS1363A 90°	90 90	Mint Gray Mint Gray	United Kingdom, Cyprus, Nigeria, Zimbabwe, Singapore
250V 	8120-1369 8120-0696	Straight ZNSS198/ASC112 90°	79 87	Gray Gray	Australia, New Zealand
250V 	8120-1689 8120-1692	Straight CEE7-VII 90°	79 79	Mint Gray Mint Gray	East and West Europe, Saudi Arabia, Egypt, Republic of So. Africa, India (unpolarized in many nations)
125V 	8120-1348 8120-1398 8120-1754 8120-1378 8120-1521 8120-1676	Straight NEMA5-15P 90° Straight NEMA5-15P Straight NEMA5-15P 90° Straight NEMA5-15P	80 80 36 80 80 36	Black Black Black Jade Gray Jade Gray Jade Gray	United States, Canada, Japan (100V or 200V), Mexico, Philippines, Taiwan
250V 	8120-2104	Straight SEV1011.1959 24507, Type 12	79	Gray	Switzerland
250V 	8120-0698	Straight NEMA6-15P			United States, Canada
220V 	8120-1957 8120-2956	Straight DHCK 107 90°	79 79	Gray Gray	Denmark
250V 	8120-1860	Straight CEE22-VI (System Cabinet Use)			

1. E = Earth Ground; L = Line; N = Neutral

2. Part number shown for plug is industry identifier for plug only. Number shown for cable is HP Part Number for complete cable including plug.

STORAGE AND SHIPMENT

Storage

Store the source modules within the following environmental limits:

Temperature	–25°C to +75°C
Humidity	Up to 95%
Altitude	Up to 4,600 kilometers (15,000 feet)

Shipment

Containers and materials identical to those used in factory packaging are available through Hewlett-Packard offices. If you choose to use commercially available materials, follow these instructions:

1. Wrap the component in heavy paper.
2. Use a strong shipping container. A double-wall carton made out of 159-kg (350-lb) test material is adequate.
3. Use shock-absorbing material, 76 to 102 mm (3 to 4 in) thick, around all sides of the instrument to provide a firm cushion and prevent movement inside the container.
4. Seal the container securely.
5. Mark the shipping container **FRAGILE**.

Returning For Service

If you are shipping any component to a Hewlett-Packard office or service center please include the following information (use the service tags at the end of this section):

1. Your company name and address.
2. A technical contact person within your company, and their complete telephone number.
3. The complete model and serial number of the component.
4. The type of service required (calibration vs. repair).
5. Any other information that may expedite service.

When making inquiries, either by correspondence or by telephone, please refer to the instrument by model number and serial number.

Manufacturer's Declaration

NOTE

This is to certify that this product meets the radio frequency interference requirements of Directive FTZ 1046/1984. The German Bundespost has been notified that this equipment was put into circulation and has been granted the right to check the product type for compliance with these requirements.

Note: If test and measurement equipment is operated with unshielded cables and/or used for measurements on open set-ups, the user must insure that under these operating conditions, the radio frequency interference limits are met at the border of his premises.

Model 83558A

NOTE

Hiermit wird bescheinigt, dass dieses Gerät/System in Übereinstimmung mit den Bestimmungen von Postverfügung 1046/84 funkentstört ist.

Der Deutschen Bundespost wurde das Inverkehrbringen dieses Gerätes/Systems angezeigt und die Berechtigung zur Überprüfung der Serie auf Einhaltung der Bestimmungen eingeräumt.

Zusatzinformation für Mess- und Testgeräte:

Werden Mess- und Testgeräte mit ungeschirmten Kabeln und/oder in offenen Messaufbauten verwendet, so ist vom Betreiber sicherzustellen, dass die Funk-Entstörbestimmungen unter Betriebsbedingungen an seiner Grundstücksgrenze eingehalten werden.

MANUAL CHANGES

The manual part number and the microfiche part number are on the title page of this manual. Either number can be used to order extra copies of the manual. Microfiche are 10 x 15 (4 x 6 in) microfilm transparencies. Each microfiche contains reduced photocopies of the manual pages.



Should one of your HP instruments need repair, the HP service organization is ready to serve you. However, you can help us serve you more effectively. When sending an instrument to HP for repair, please fill out this card and attach it to the product. Increased repair efficiency and reduced turn-around time should result.

COMPANY _____

ADDRESS _____

TECHNICAL CONTACT PERSON _____

PHONE NO. _____ EXT. _____

MODEL NO. _____ SERIAL NO. _____

MODEL NO. _____ SERIAL NO. _____

P.O. NO. _____ DATE _____

Accessories returned with unit

NONE CABLE(S)

POWER CABLE ADAPTER(S)

OTHER _____ over



Should one of your HP instruments need repair, the HP service organization is ready to serve you. However, you can help us serve you more effectively. When sending an instrument to HP for repair, please fill out this card and attach it to the product. Increased repair efficiency and reduced turn-around time should result.

COMPANY _____

ADDRESS _____

TECHNICAL CONTACT PERSON _____

PHONE NO. _____ EXT. _____

MODEL NO. _____ SERIAL NO. _____

MODEL NO. _____ SERIAL NO. _____

P.O. NO. _____ DATE _____

Accessories returned with unit

NONE CABLE(S)

POWER CABLE ADAPTER(S)

OTHER _____ over



Should one of your HP instruments need repair, the HP service organization is ready to serve you. However, you can help us serve you more effectively. When sending an instrument to HP for repair, please fill out this card and attach it to the product. Increased repair efficiency and reduced turn-around time should result.

COMPANY _____

ADDRESS _____

TECHNICAL CONTACT PERSON _____

PHONE NO. _____ EXT. _____

MODEL NO. _____ SERIAL NO. _____

MODEL NO. _____ SERIAL NO. _____

P.O. NO. _____ DATE _____

Accessories returned with unit

NONE CABLE(S)

POWER CABLE ADAPTER(S)

OTHER _____ over



Should one of your HP instruments need repair, the HP service organization is ready to serve you. However, you can help us serve you more effectively. When sending an instrument to HP for repair, please fill out this card and attach it to the product. Increased repair efficiency and reduced turn-around time should result.

COMPANY _____

ADDRESS _____

TECHNICAL CONTACT PERSON _____

PHONE NO. _____ EXT. _____

MODEL NO. _____ SERIAL NO. _____

MODEL NO. _____ SERIAL NO. _____

P.O. NO. _____ DATE _____

Accessories returned with unit

NONE CABLE(S)

POWER CABLE ADAPTER(S)

OTHER _____ over



Should one of your HP instruments need repair, the HP service organization is ready to serve you. However, you can help us serve you more effectively. When sending an instrument to HP for repair, please fill out this card and attach it to the product. Increased repair efficiency and reduced turn-around time should result.

COMPANY _____

ADDRESS _____

TECHNICAL CONTACT PERSON _____

PHONE NO. _____ EXT. _____

MODEL NO. _____ SERIAL NO. _____

MODEL NO. _____ SERIAL NO. _____

P.O. NO. _____ DATE _____

Accessories returned with unit

NONE CABLE(S)

POWER CABLE ADAPTER(S)

OTHER _____ over



Should one of your HP instruments need repair, the HP service organization is ready to serve you. However, you can help us serve you more effectively. When sending an instrument to HP for repair, please fill out this card and attach it to the product. Increased repair efficiency and reduced turn-around time should result.

COMPANY _____

ADDRESS _____

TECHNICAL CONTACT PERSON _____

PHONE NO. _____ EXT. _____

MODEL NO. _____ SERIAL NO. _____

MODEL NO. _____ SERIAL NO. _____

P.O. NO. _____ DATE _____

Accessories returned with unit

NONE CABLE(S)

POWER CABLE ADAPTER(S)

OTHER _____ over

Service needed

- CALIBRATION ONLY
- REPAIR REPAIR & CAL

OTHER _____

Observed symptoms/problems

FAILURE MODE IS:

- CONSTANT INTERMITTENT

SENSITIVE TO:

- COLD HEAT VIBRATION

FAILURE SYMPTOMS/SPECIAL CONTROL SETTINGS _____

If unit is part of system list model number(s) of other interconnected instruments. _____

9320-3896 Printed in U.S.A.

Service needed

- CALIBRATION ONLY
- REPAIR REPAIR & CAL

OTHER _____

Observed symptoms/problems

FAILURE MODE IS:

- CONSTANT INTERMITTENT

SENSITIVE TO:

- COLD HEAT VIBRATION

FAILURE SYMPTOMS/SPECIAL CONTROL SETTINGS _____

If unit is part of system list model number(s) of other interconnected instruments. _____

9320-3896 Printed in U.S.A.

Service needed

- CALIBRATION ONLY
- REPAIR REPAIR & CAL

OTHER _____

Observed symptoms/problems

FAILURE MODE IS:

- CONSTANT INTERMITTENT

SENSITIVE TO:

- COLD HEAT VIBRATION

FAILURE SYMPTOMS/SPECIAL CONTROL SETTINGS _____

If unit is part of system list model number(s) of other interconnected instruments. _____

9320-3896 Printed in U.S.A.

Service needed

- CALIBRATION ONLY
- REPAIR REPAIR & CAL

OTHER _____

Observed symptoms/problems

FAILURE MODE IS:

- CONSTANT INTERMITTENT

SENSITIVE TO:

- COLD HEAT VIBRATION

FAILURE SYMPTOMS/SPECIAL CONTROL SETTINGS _____

If unit is part of system list model number(s) of other interconnected instruments. _____

9320-3896 Printed in U.S.A.

Service needed

- CALIBRATION ONLY
- REPAIR REPAIR & CAL

OTHER _____

Observed symptoms/problems

FAILURE MODE IS:

- CONSTANT INTERMITTENT

SENSITIVE TO:

- COLD HEAT VIBRATION

FAILURE SYMPTOMS/SPECIAL CONTROL SETTINGS _____

If unit is part of system list model number(s) of other interconnected instruments. _____

9320-3896 Printed in U.S.A.

Service needed

- CALIBRATION ONLY
- REPAIR REPAIR & CAL

OTHER _____

Observed symptoms/problems

FAILURE MODE IS:

- CONSTANT INTERMITTENT

SENSITIVE TO:

- COLD HEAT VIBRATION

FAILURE SYMPTOMS/SPECIAL CONTROL SETTINGS _____

If unit is part of system list model number(s) of other interconnected instruments. _____

9320-3896 Printed in U.S.A.

Source System Guides

Section 2. Source System Guides

INTRODUCTION

The HP 83558A millimeter-wave source module extends the frequency range of 12.5 to 18.33 GHz sources to 75.0 to 110.0 GHz (W-band). This mm-wave source module is enhanced by the performance features of HP microwave source drivers such as the HP 83550A and 83592C/95C RF plug-ins, the HP 8341B (Opt. 003) synthesized sweepers, the HP 8673C/D synthesized signal generators, and the HP 83623A/24A synthesized sweepers.

This section of the manual provides information that will enable you to use the source module in different mm-wave source system configurations. Each system configuration is separately documented in its own Source System Guide (sections 2a through 2e), addressing each according to source driver and applications. The individual guides also provide system specifications, connection diagrams, operating characteristics, performance tests, and troubleshooting sections.

RECOMMENDED TEST EQUIPMENT

Test equipment required for system performance testing is given in Table 2-1. If substitute equipment is used, it must meet the critical specifications shown in the table.

SPECIFICATIONS

The HP 83558A source module uses frequency multiplication to generate mm-wave frequencies. The frequency specifications are directly proportional to those of the external signal source driving the source module. Therefore, those specifications are extensions of the specified signal source and are detailed in each source system guide. The output characteristic specifications are source module specific and are detailed in the Source Module Specifications and Service Section.

OPERATION

The operation portion of the applicable source system guide will enable you to use the HP 83558A source module in a variety of applications. Included are system hookup diagrams that illustrate the source module in a systems environment, test procedures that cover the measurement system, and operational suggestions.

PERFORMANCE TESTS

The test procedures in these sections test the electrical performance of the HP 83558A with a specified source driver in a systems configuration. These tests reference the System Specifications table of each Source System Guide as the performance standards against which the system is tested.

SYSTEM LEVEL TROUBLESHOOTING

Within each Source System Guide is a System Level Troubleshooting section to help isolate system failures to an instrument level. Once an instrument is isolated as the failure, references to the specific Operating and Service manual are made for repair procedures.

Table 2-1. Recommended Test Equipment

Instrument	Critical Specifications	Recommended Model	Use ¹
Spectrum Analyzer	12.5 to 18.33 GHz coverage	HP 8566B	P
Power Meter	-10 to +20 dBm power coverage	Anritsu ML83A	O,P,T
Power Sensor	-10 to +20 dBm power coverage with 75.0 to 110.0 GHz frequency coverage	Anritsu MP81B	O,P,T
Microwave Amplifier	2.0 to 8.0 GHz range	HP 11975A	P
Harmonic Mixer	75.0 to 110.0 GHz frequency coverage	HP 11970W	P
Waveguide Directional Coupler, 10 dB	75.0 to 110.0 GHz frequency coverage with >30 dB directivity	HP W752C	O,P
Waveguide Directional Coupler, 20 dB	75.0 to 110.0 GHz frequency coverage with >30 dB directivity	HP W752D	O,P
Detector Adapter	AC detector adapter (75.0 to 110.0 GHz)	HP 85025C	O
Detector	75.0 to 110.0 GHz frequency coverage	HP 85025C K71	O
Cables (2)	3.5 mm connectors	HP P/N 5061-5458	O,P,T
Cables (5)	BNC connectors	HP P/N 8120-1839	
Cables (2)	Type-N male connectors 8 to 20 GHz range, SWR \leq 1.45 to 1, insertion loss \leq 2 dB	HP P/N 5061-5359	O,P,T

1. O = Operation; P = Performance Test; T = Troubleshooting

HP 83550A/HP 8350B
Source System Guide

TABLE of CONTENTS
HP 83550A SOURCE SYSTEM GUIDE

Introduction
System Specifications
Operation
Operator's Check
System Performance Tests
Introduction
Frequency Characteristics
Troubleshooting

Section 2a. HP 83550A Source System Guide

INTRODUCTION

This source system guide provides mm-wave system operating information for the HP 83550A/8350B/83558A system (unless otherwise stated, hereafter referred to as the HP 83550A/83558A system). It contains an operator's check, connection diagrams, system specifications, system performance tests, and system level troubleshooting. For detailed instructions regarding the operation or troubleshooting of the individual instruments, refer to the instrument's operating and service manual.

SYSTEM DESCRIPTION

The HP 83550A is an 8 to 20 GHz RF plug-in used with the HP 8350B sweep oscillator. It provides a minimum of +17 dBm of internally leveled calibrated output power and a built-in mm-wave source module interface to serve as a direct microwave source driver for the HP 83558A source module.

NOTE: With Option 002 (50 dB programmable attenuator), the HP 83550A may not drive the source module to full specified output power. Refer to the HP 83550A Operating and Service Manual for detailed specifications.

For proper display accuracy, leveling flatness, and harmonic suppression, the HP 83550A 1.0/0.5V/GHz frequency reference output switch must be set to 0.5V/GHz. For further information, refer to the HP 83550A Operating and Service Manual.

WARNING

This equipment is capable of radiating millimeter-wave energy from the end of unterminated waveguide. Do not look directly into the open end of any waveguide when it is connected to a source of millimeter-wave energy.

Take precautions consistent with ANSI C95.1 - 1982, a study performed by the American National Standards Institute that sets limits for human exposure to microwave and millimeter-wave energy. Copies of this publication are available from:

**American National Standards Institute
1430 Broadway
New York, N. Y. 10018**

SYSTEM SPECIFICATIONS

Table 2a-1 provides system specifications for the HP 83550A/83558A system configuration. These are the performance standards against which the system is tested.

Table 2a-1. HP 83550A/83558A System Specifications

Frequency Characteristics	Modulation Characteristics
Range 75.0 to 110.0 GHz	External FM
Accuracy (25°C ± 5°C) ¹	Maximum Deviations for Modulation Frequencies
CW Mode ± 120 MHz	Crossover Coupled
All Sweep Modes	DC to 100 Hz ± 450 MHz
(for sweep time > 100 msec) ± 300 MHz	100 Hz to 6 MHz ± 81 MHz
CW Resolution 156 kHz	Sensitivity
Stability	FM Mode, typically - 120 MHz/V
With Temperature, typically ± 6 MHz/°C	Phase-Lock Mode, typically - 36 MHz/V
With 10% Line Voltage Change ± 900 kHz	External AM
With Time (in a 10-minute period) ¹ .. < ± 6 MHz	Bandwidth, typically DC to 100 kHz
Residual FM. Peak (20 Hz to 15 KHz	Sensitivity, typically 1 dB/V
bandwidth), (CW mode) < 150 kHz	External Pulse Modulation
	Rise/Fall Time, typically 25 ns
	Minimum RF Pulse Width
	System Leveled, typically 1 us
	On/off ratio, typically > 60 dB
	Pulse Repetition Frequency
	System Leveled 10 Hz to 500 kHz
	System Unleveled DC Hz to 5 MHz
	HP 8756A, 8757A
	AC Detection Mode Compatibility Yes

1. After one hour warmup at selected CW frequency.

OPERATION

INTRODUCTION

This section is intended for operators familiar with the HP 83550A. If you are unfamiliar with this system, refer to the Operator's Check at the end of this section for verification of system operation.

In the operation instructions, instrument settings and function keys are surrounded by the [] symbols.

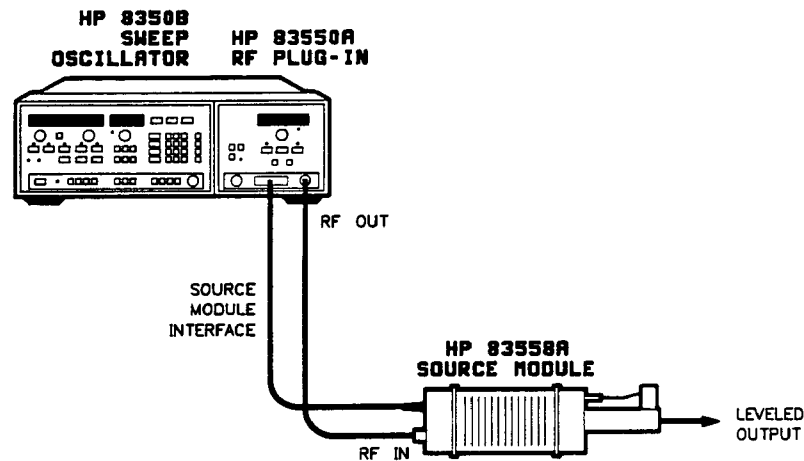

Figure 2a-1. HP 83550A/83558A Source System Configuration



Turn HP 8350B ac power OFF before connecting or disconnecting the source module interface cable.

Connect the system as shown in Figure 2a-1.

FREQUENCY CONTROL

Turn on the HP 8350B and press [INSTR PRESET]. The HP 8350B will be automatically initialized to the frequency range of the HP 83558A. You can then choose the appropriate mm-wave frequency you desire from the front panel of the HP 8350B.

Both the HP 8350B and 83550A have built-in self diagnostic and mm-wave source module related error codes to help the user. These error codes will be displayed on the HP 8350B START frequency or RF plug-in POWER level displays should an error occur. For a complete list of these codes, refer to the section titled TROUBLESHOOTING in this guide.

If the HP 83550A is to be used only as an RF plug-in with a frequency range of 8 to 20 GHz, turn off the system, remove the mm-wave source module, then turn the system on again. Otherwise, the HP 83550A will still perform as if connected to the millimeter-wave source module.

POWER LEVEL CONTROL



Before performing any power level calibrations, ensure that the HP 83550A is not at maximum power.

The RF output power of the mm-wave source module is read on the HP 83550A RF plug-in display in this configuration. The output power is controlled by the Power Level Control on the RF plug-in front panel.

When using an HP 83558A (Opt. 001) with an HP 83550A, the output power is unleveled. To provide power control capability with the HP 83558A (Opt. 001), the firmware in the HP 83550A has been upgraded to Revision 6.1. To activate the power control feature, press **[SHIFT] [8] [3]**. To return to leveling with the external signal (standard instrument only), press **[SHIFT] [8] [2]**.

If your HP 83550A does not have firmware revision 6.1 or later, order kit number 83550-90143 to upgrade the firmware.

POWER LEVELING

System Leveling

The HP 83550A/83558A system configuration shown in Figure 2a-1 provides source module leveled output power with corrected power level flatness. When the HP 83550A INT key is active, a portion of the mm-wave power output is sampled using a directional coupler and detector external to the mm-wave source module. This signal is applied to the HP 83550A automatic leveling control circuitry (ALC). The source module output level is displayed on the HP 83550A power display.

External Power Meter Leveling

Output power may also be leveled with a power meter and a directional coupler as shown in Figure 2a-2. Power meter leveling at the mm-wave source module output is possible using the power meters referenced in Table 1-1 (System General Information).

Set the ALC mode to **[MTR]** on the HP 83550A. For best swept accuracy, set the sweep time to 100 seconds when this leveling method is used. A portion of the mm-wave output signal from the source module is coupled/detected and routed to the power meter. The DC voltage from the power meter's recorder output is applied to the HP 83550A ALC input.

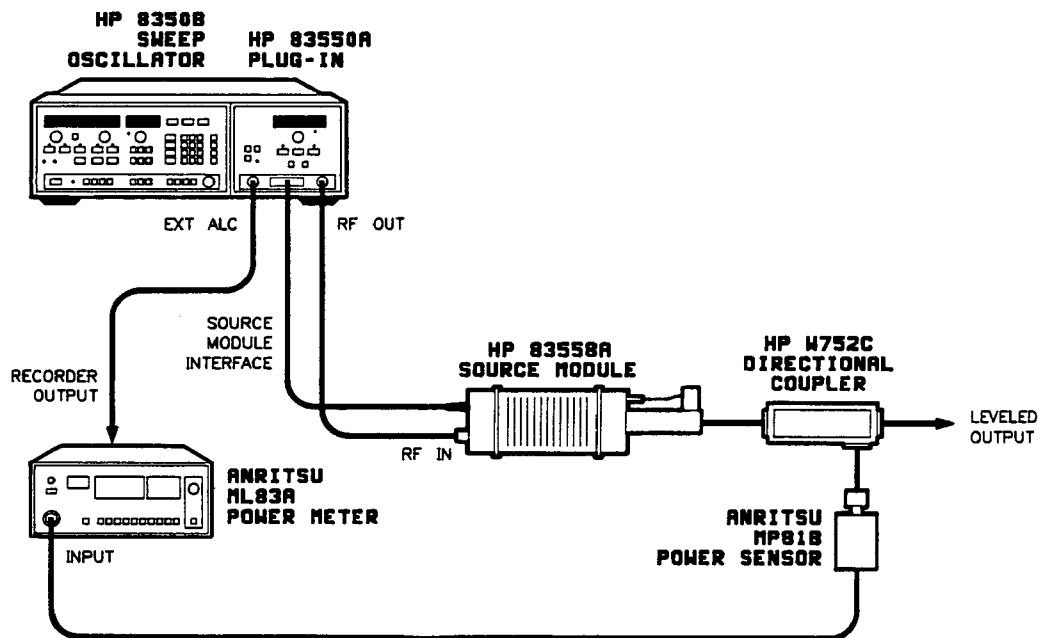

Figure 2a-2. External Power Meter Leveling at the HP 83558A Output

MODULATION

For complete specifications on all three modulation modes described below, refer to Table 2a-1 (HP 83550A/83558A System Specifications).

Frequency Modulation (FM INPUT Connector on HP 8350B)

The HP 83550A/83558A system configuration output signal can be frequency modulated using an external modulating signal applied to the HP 8350 rear panel FM INPUT connector.

The sensitivity and maximum deviations of the HP 83550A are multiplied by a factor of six since the HP 83558A source module multiplies the frequency by six. The sensitivity of the modulating signal may be set via configuration switch A3S1 on the HP 83550A RF plug-in. The following configuration switch settings override HP 8350 non-volatile memory settings at instrument preset. If the configuration switch is changed, you must press Instrument Preset again to load the memory with the new sensitivity settings.

The following is an example of the HP 83550A RF plug-in configuration switch settings. Refer to the HP 83550A Operating and Service manual for further details. The sensitivity setting for the overall system will be multiplied by six, -36 MHz/V and -120 MHz/V.

Description	A3S1 Switch Number	
	5	6
-6 MHz/V FM Sensitivity	1	1
-20 MHz/V FM Sensitivity	0	X
Cross-over Coupled	X	X

NOTE: 1 = High
0 = Low
X = Don't Care

Amplitude Modulation (AM INPUT Connector on HP 8350B)

The AM INPUT provides amplitude changes (up to approximately 5 dB) proportional to the modulating voltage. The sensitivity is typically 1 dB/V. The AM is typically limited to a frequency response of DC to 100 kHz.

Maximum depth of modulation can be achieved by starting at the maximum power, and decreasing down to the minimum power level possible from the source module. For maximum modulation index, the HP 83558A source module should be set to a power level such that the peak of the modulation waveform does not exceed the maximum specified power level.

Pulse Modulation (PULSE IN Connector)

The application of a pulsed or square wave signal to the PULSE IN connector provides a pulse or square wave modulated signal at the output of the HP 83558A. This input provides an ON/OFF power ratio of typically greater than 60 dB. The PULSE IN input is normally at a TTL HIGH (approximately +3 volts DC). When a TTL LOW signal (approximately 0 volts DC) is applied, the source module output signal is turned off.

With system leveled power, pulse repetition rates from 10 Hz to 500 kHz are achievable.

OPERATOR'S CHECK

DESCRIPTION

The following procedure will enable you to verify the proper operation of your HP 83550A/83558A system by determining the system's output power and flatness performance over the W-band frequency range of 75.0 to 110.0 GHz at the maximum leveled output power of 0 dBm.

EQUIPMENT

Ensure that all the instruments below meet their own performance standards and have been recently calibrated to proper specifications before configuring them into the setup.

RF Signal Source	HP 8350B/HP 83550A RF Plug-in
Power Meter	Anritsu ML83A
Power Sensor	Anritsu MP81B

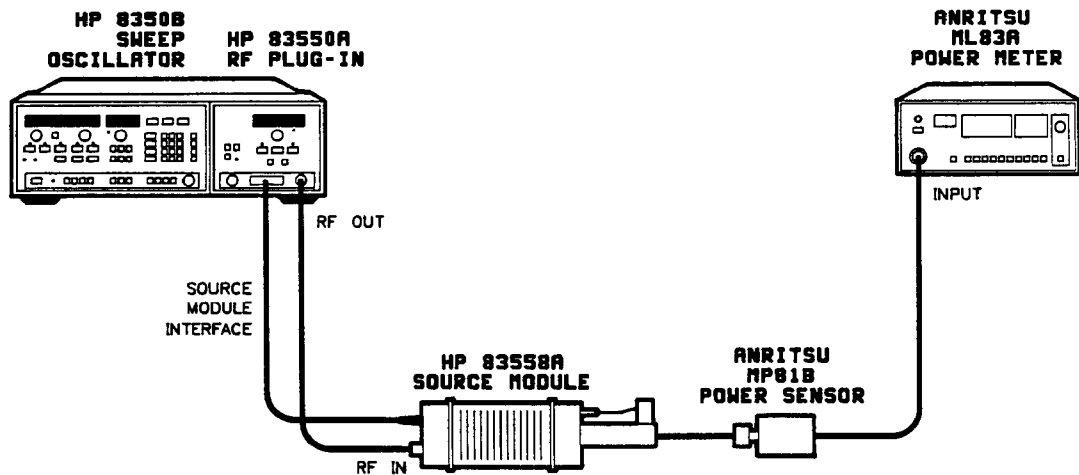

Figure 2a-3. System Configuration

PROCEDURE

1. Connect the equipment as shown in Figure 2a-3. Do not connect the power sensor to the HP 83558A output.



Turn off the ac power on the HP 8350B prior to connecting or disconnecting from the source module interface connector.

2. Turn on all system components.
3. On the power meter:

Press [dBm] mode.

Zero and calibrate the power meter. Set the CAL FACTOR at 100%. The CAL FACTOR will **not** be changed for the rest of the procedure. By leaving the CAL FACTOR set at 100% it ensures testing for worst case errors.

4. On the HP 8350B:

Press [SHIFT] [INSTRUMENT PRESET]

NOTE: The HP 83550A RF plug-in has built in self diagnostic and source module related error codes to help the user. These error codes are displayed on the HP 8350B START frequency or RF plug-in POWER level displays should an error occur. For a complete list of these codes, refer to the section titled TROUBLESHOOTING in this guide.

Press [START] [7] [5] [.] [0] [GHz]

Press [STOP] [1] [1] [0] [.] [0] [GHz]

Press [MAN] SWEEP and adjust the FREQUENCY/TIME rotary knob for a 75.0 GHz frequency reading.

NOTE: Ensure that the [L] MOD button is off or it will affect the power level indication on the power meter.

5. On the HP 83550A:

Press [INT] ALC MODE to put the system in the system leveled mode.

Press [POWER LEVEL]

Adjust the power level rotary knob for a 0 dBm reading on the RF plug-in display.

Connect the power sensor to the HP 83558A output.

Adjust the power level rotary knob for a 0 dBm reading on the power meter display.

6. On the HP 8350B:

Find the minimum power point between 75.0 GHz and 110.0 GHz by slowly adjusting the FREQUENCY/TIME rotary knob from 75.0 GHz to 110.0 GHz and reading the power meter display. Note at what frequency the minimum power point occurs. See Figure 2a-4.

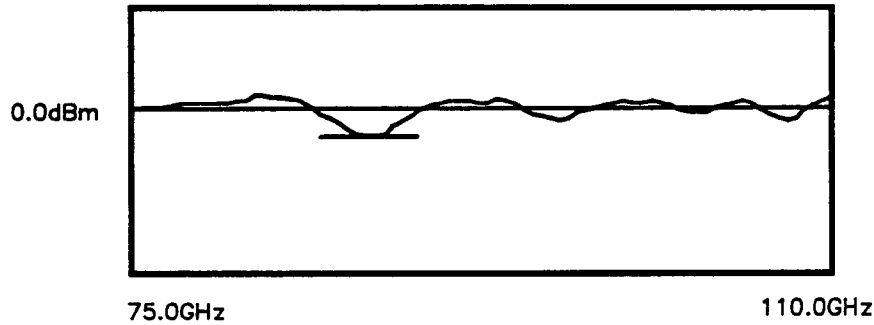

Figure 2a-4. Minimum Power Point (75.0 to 110.0 GHz)

Enter the frequency of the minimum power point by pressing [CW] XX.XX [GHz].

7. On the HP 83550A:

Adjust the power level rotary knob until the power meter display reads 0 dBm, thus ensuring the minimum power point is at maximum specified output power.

8. On the HP 8350B:

Press [START] [7] [5] [.] [0] [GHz]

Press [STOP] [1] [1] [0] [.] [0] [GHz]

Slowly adjust the FREQUENCY/TIME rotary knob from 75.0 to 110.0 GHz on the FREQUENCY/TIME display. Observe the power meter display through the entire manual sweep making sure that the power level displayed never exceeds +4.0 dBm. This ensures that from 75.0 to 110.0 GHz, the system's power flatness is within ± 2.0 dB of maximum leveled power, 0 dBm. See Figure 2a-5.

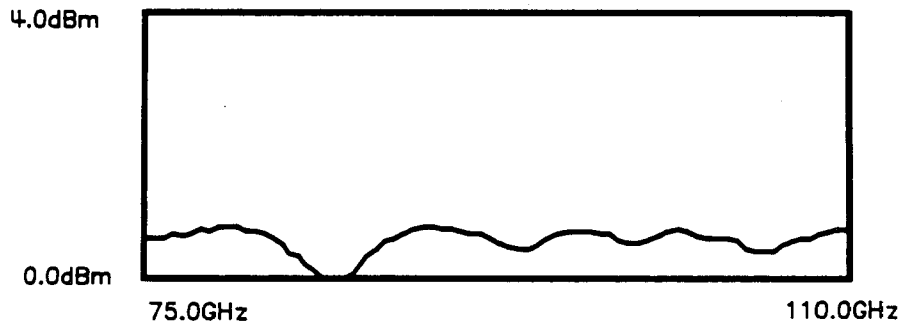

Figure 2a-5. Power Flatness Response (75.0 to 110.0 GHz)

This completes the Operator's Check. If your system fails this functional check refer to the paragraph titled TROUBLESHOOTING.

SYSTEM PERFORMANCE TESTS

INTRODUCTION

The procedures in this section test the performance of the HP 83550A/83558A System using the specifications of Table 2a-1 as the performance standards. All tests can be performed without access to the interior of the instrument. The performance test procedures must be performed in the sequence given since some procedures rely on satisfactory test results in the foregoing steps. In order to fully verify the performance specifications of the HP 83558A, the performance tests in the Source Module Specifications and Service section must also be performed. None of the tests require access to the interior of the instrument.

Under the paragraph TROUBLESHOOTING, you will find information on what to do if your system fails to meet specifications.

EQUIPMENT REQUIRED

Equipment required for the performance tests is listed in the Recommended Test Equipment tables in the Source System Guides and the Source Module Specifications and Service Section. Any equipment that satisfies the critical specifications given in the table may be substituted for the recommended models. Ensure also that the test equipment used is currently calibrated to proper specifications.

NOTE: Use only the connectors and cables that are specified in the following test setups to ensure accurate test results.

OPERATION VERIFICATION

The Operation Verification consists of performing the source module specific performance tests (Source Module Specifications and Service Section) which include, Maximum Leveled Power (verifies frequency range), Power Flatness, and Power Level Accuracy. These tests provide reasonable assurance that the source module is functioning properly and should meet the needs of an incoming inspection (80% verification).

TEST RECORD

Results of the performance tests may be recorded in the Test Record at the end of the procedures. The Test Record lists all of the tested specifications and their acceptable limits. Test results recorded at incoming inspection can be used for comparison in periodic maintenance and troubleshooting or after repairs.

FREQUENCY CHARACTERISTICS

Range
Accuracy
CW Resolution
Stability

MODULATION CHARACTERISTICS

External FM

The performance tests listed above are source dependent and can be found in the Performance Tests of the HP 83550A RF plug-in Operating and Service manual.

NOTE: When specifying the output frequency and modulation characteristics of the HP 83550A/83558A system, all specifications will be referenced from the source and must be multiplied by six because the HP 83558A multiplies the frequency by six. For special information about the multipliers, refer to the "Theory of Operation" section found in the "Source Module Specifications and Service" section of this manual.

Table 2a-2. Performance Test Record

<p>HP 83550A System</p> <p>Serial Number _____ Date _____</p> <p>Humidity* _____ Tested By _____</p> <p>*(Optional) Temperature* _____</p>				
Specification Tested	Test Conditions	Specification	Test Results	
			Pass	Fail
FREQUENCY				
Range ¹	_____	75.0 to 110.0 GHz ¹	_____	_____
Accuracy ¹	_____	± 120 MHz ¹	_____	_____
Resolution ¹	_____	156 kHz ¹	_____	_____
Stability ¹				
With Temperature, typically	_____	± 6 MHz/°C ¹	_____	_____
With 10% Line Voltage Change	_____	± 900 kHz ¹	_____	_____
With Time (in a 10 min period)	_____	< ± 6 MHz ¹	_____	_____
Residual FM, Peak (20 Hz to 15 kHz BW, CW Mode)	_____	< 150 kHz ¹	_____	_____
MODULATION				
External FM Maximum Deviations for Modulation				
Frequencies Crossover Coupled DC to 100 Hz	_____	± 450 MHz ¹	_____	_____
100 Hz to 6 MHz	_____	± 81.0 MHz ¹	_____	_____

1. These specifications are six times those of the HP 83550A specifications because the HP 83558A multiplies the frequency by six.

TROUBLESHOOTING

Specification Failures

Failures are divided into two categories:

Category one describes systems that are meeting specifications in some areas, while failing in others. If this is the case, do the following:

Inspect the connectors and ensure that all connections are making good electrical contact.

Inspect all cabling for breaks.

Test again.

If your system is still failing at the SAME points, your instrument(s) or cable(s) could be defective and should be returned for repair. If, however, your system fails at DIFFERENT points, there is probably a loose connection or a mechanical failure somewhere in the setup.

Remember, it is possible the system may fail the performance test(s) because of measurement uncertainties. If you suspect this to be the case, contact your nearest HP office for more information.

Category two failures are total specification failures. If your system fails any of these tests completely, do the following:

Check the TEST SETUP for correct configuration of the instruments and connections.

Inspect the connectors.

Inspect the cables.

Repeat the failed test(s).

If your system is still failing, the system is probably defective and needs repair.

Also, for the best accuracy in measurement, use only calibrated instruments.

Error Codes

The HP 8350B sweep oscillator and the HP 83550A RF plug-in have a series of internal power-on self tests which will indicate an error code on either the HP 8350B frequency or HP 83550A power displays should a failure occur.

Error codes E001 through E016 are specific to the HP 8350B and indicate a possible failure in the sweep oscillator. Refer to the HP 8350B Operating and Service Manual for information and troubleshooting procedures.

Error codes E050 through E079 are specific to the HP 83550A and indicate a possible failure in the RF plug-in. Refer to the HP 83550A Operating and Service Manual for information and troubleshooting procedures.

Error codes E080 through E086 are specific to the HP 83558A and indicate a possible failure in the source module. Table 2a-3 lists the error codes with descriptions and possible error location.

Table 2a-3. HP 83550A/83558A System Error Codes (1 of 2)

Error Code Displayed	Error Code Description	Possible Location	Cause
E080	Source Module Digital Interface	HP 83558A-A5	On power-up and instrument preset the HP 83550A will attempt to read known constants in predefined source module NOVRAM addresses. If these constants are not returned correctly, the error indicates a problem with the module interface cable or the digital interface assembly in the source module.

This interface error can be isolated to either the HP 83550A RF plug-in or to the HP 83558A source module by initiating a Source Module Digital Interface Cycle Test. This test verifies that the digital signals necessary for proper source module operation are propagating from the HP 83550A RF plug-in source module digital interface connector. This can be performed as follows:

Turn off the HP 8350B ac power and disconnect the source module from the HP 83550A.

On the HP 8350B:
Switch the ac power to on.
Press [SHIFT] [8] [0]

Using an oscilloscope, compare the digital interface lines out of the RF plug-in interface connector to the following waveforms. If all the waveforms are present, the error location is either in the source module interface cable or within the source module itself. Should the problem lie in the HP 83550A, refer to the HP 83550A Operating and Service Manual for further troubleshooting information.

Test Pin Location	
HP 83550A A3TP7	
Source Module Interface Connector	Test Trigger
pin 18	MOD D0
pin 19	MOD D1
pin 10	MOD D2
pin 20	MOD D3
pin 8	MOD C0
pin 9	MOD C1

Table 2a-3. HP 83550A/83558A System Error Codes (2 of 2)

Error Code Displayed	Error Code Description	Possible Location	Cause
E081	Source Module NOVRAM Checksum Error	HP 83558A-A5	On power-up and instrument preset, a checksum test is performed on the source module NOVRAM data. If the test fails the error will be displayed.
E082	Source Module +8 VDC Supply Failure	HP 83550A-A3	The +8 VDC power supply is used exclusively for source module operation and this error is indicated when the HP 83550A self-test board measurement of the +8 VDC supply is not within the allowed tolerance.
NOTE: This test is not performed upon power-up or instrument preset unless a source module is connected to the RF plug-in.			
E083	Source Module 0.5 V/GHz Failure	HP 83550A-A5	This error code is indicated when a failure in the 0.5 V/GHz signal has been detected. The test presets the RF plug-in to two known states where the 0.5 V/GHz voltage is at known values. The error is indicated if the measurements do not match the known values.
NOTE: This test is not performed upon power-up or instrument preset unless a source module is connected to the RF plug-in.			
E084	Source Module ALC Failure	HP 83558A-A5	<p>This test measures the logged detector voltage from the source module interface connector. The general integrity of the ALC circuitry and the RF chain is checked when the RF plug-in is in the system leveling mode of operation. This voltage is approximately 0 VDC with the power offset value in the source module memory (0 dBm for the HP 83558A) with a slope of 40 mv/dB.</p> <p>The self test sets the RF plug-in to the minimum settable power for the source module. The power should be leveled at this ALC voltage. The error is indicated if the measured voltage is not within tolerances.</p>
NOTE: This test is not performed upon power-up or instrument preset unless a source module is connected to the RF plug-in. Also, this test is not performed if the RF plug-in is configured for NO RF power at instrument power-up.			

HP 83592C or 95C/HP 8350B
Source System Guide

TABLE of CONTENTS
HP 83592C/95C SOURCE SYSTEM GUIDE

Introduction
System Specifications
Operation
Operator's Check
System Performance Tests
Introduction
Frequency Characteristics
Troubleshooting

Section 2b. HP 83592C/95C Source System Guide

INTRODUCTION

This source system guide is intended to provide you with mm-wave system operating information for the HP 83592C/95C RF plug-ins. It contains an operator's check, connection diagrams, system specifications, system performance tests, and system level troubleshooting. For detailed instructions regarding the operation or troubleshooting of the individual instruments refer to the instrument's operating and service manual.

SYSTEM DESCRIPTION

The HP 83592C/95C RF plug-ins cover the frequency range of 10 MHz to 26.5 GHz. The combination of the HP 83592C/95C RF plug-ins/8350B sweep oscillator with an HP 8349B microwave amplifier delivers the required input power of +17 dBm from 12.5 to 18.33 GHz for the HP 83558A millimeter-wave source module.

For proper display accuracy, leveling flatness, and harmonic suppression, the HP 83592C/95C plug-in's 1V/GHz output will have to be modified for a 0.5V/GHz output. If the serial number prefix of your plug-in matches or exceeds 2602A, the 0.5V, 1.0V/GHz frequency reference output is switch selectable on the A2 interface assembly. Refer to the HP 83592C/95C Operating and Service manuals or the latest manual change sheet.

Also, for best ALC and pulse performance and the ability to externally power meter level with the Anritsu power meter, it is a requirement that the HP 83592C/95C have the latest version of the A4-ALC assembly. Another requirement is the sweep control assembly. It must be the latest revision to allow external leveling at lower RF plug-in output powers when used in millimeter-wave applications. If the serial number prefix of your plug-in matches or exceeds any of the prefixes listed in the box below, the latest version of the A4-ALC and A6-sweep control assemblies are already installed.

RF Plug-in	Lowest Serial Number Prefix with the Required A4 and A6 Assemblies
83592C 83595C	2412A All Prefixes

WARNING

This equipment is capable of radiating millimeter-wave energy from the end of unterminated waveguide. Do not look directly into the open end of any waveguide when it is connected to a source of millimeter-wave energy.

Take precautions consistent with ANSI C95.1 - 1982, a study performed by the American National Standards Institute that sets limits for human exposure to microwave and millimeter-wave energy. Copies of this publication are available from:

American National Standards Institute
1430 Broadway
New York, N. Y. 10018

SYSTEM SPECIFICATIONS

Table 2b-1 provides specifications for the HP 83592C/95C RF plug-in/83558A system configuration. These are the performance standards against which the system is tested.

Table 2b-1. HP 83592C/95C/83558A System Specifications

<p>Frequency Characteristics</p> <p>Range 75.0 to 110.0 GHz</p> <p>Accuracy (25°C ± 5°C)</p> <p> CW Mode ± 60 MHz</p> <p>All Sweep Modes (for sweep time > 100 msec) ± 180 MHz</p> <p>CW Resolution 156 kHz</p> <p>Stability</p> <p> With Temperature, typically ± 3.6 MHz/°C</p> <p> With 10% Line Voltage Change ± 900 kHz</p> <p> With Time (in a 10-minute period)¹ .. < ± 1800 kHz</p> <p> Residual FM. Peak (20 Hz to 15 kHz bandwidth) (CW mode) < 54 kHz</p> <p>Modulation Characteristics</p> <p>External FM</p> <p>Maximum Deviations for Modulation Frequencies</p> <p> Crossover Coupled</p> <p> DC to 100 Hz ± 450 MHz</p> <p> 100 Hz to 1 MHz ± 42 MHz</p> <p> 1 MHz to 2 MHz ± 30 MHz</p> <p> 2 MHz to 10 MHz ± 6 MHz</p>	<p>Modulation Characteristics (Cont'd)</p> <p>Direct Coupled</p> <p> DC to 100 Hz ± 72 MHz</p> <p> 100 Hz to 1 MHz ± 42 MHz</p> <p> 1 MHz to 2 MHz ± 30 MHz</p> <p> 2 MHz to 10 MHz ± 6 MHz</p> <p>Sensitivity</p> <p> FM Mode, typically - 120 MHz/V</p> <p> Phase-Lock Mode, typically - 36 MHz/V</p> <p>External AM</p> <p> Bandwidth, typically DC to 100 kHz</p> <p> Sensitivity, typically 1 dB/V</p> <p>External Pulse Modulation</p> <p> Rise/Fall Time, typically 10 ns</p> <p> Minimum RF Pulse Width</p> <p> System Leveled, typically 1 μs</p> <p> On/Off Ratio, typically > 80 dB</p> <p> Pulse Repetition Frequency</p> <p> System Leveled 100 Hz to 500 KHz</p> <p> System Unleveled 100 Hz to 5 MHz</p> <p>HP 8756A, 8757A</p> <p> AC Detection Mode Compatability Yes</p>
--	--

1. After one hour warmup at selected CW frequency.

OPERATION

INTRODUCTION

This section is intended for operators familiar with the HP 8350B/83592C/95C series instruments. If you are unsure, refer to the Operators Check at the end of this section for more specific instructions.

In the operation instructions, any instrument setting or function key is defined by the [] symbols around it.

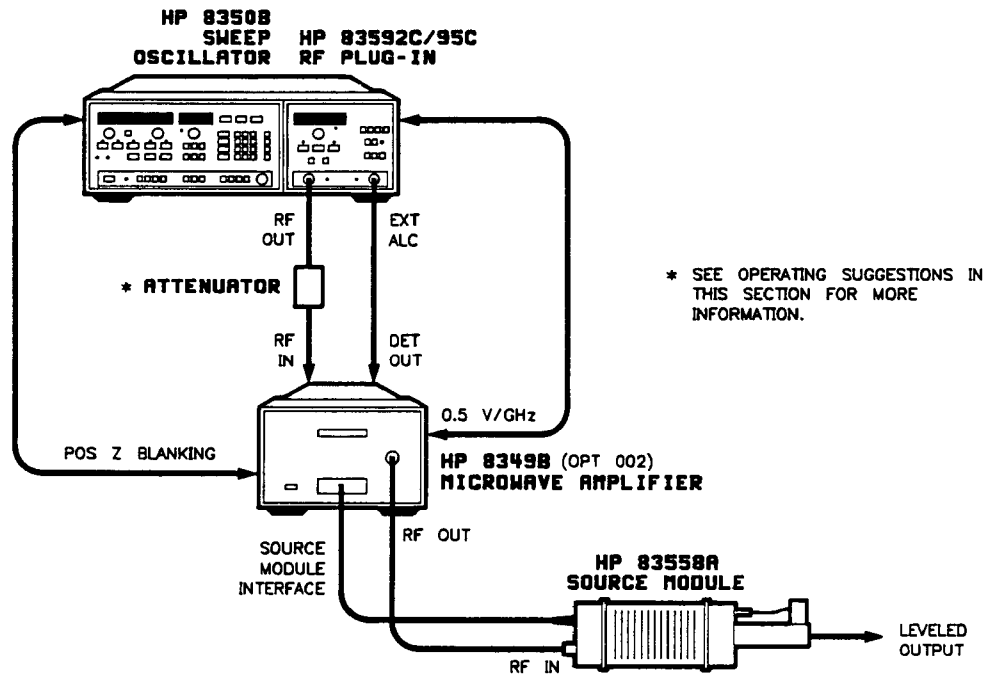

Figure 2b-1. HP 83592C/95C/83558A Source System Configuration



Turn off the ac power on the HP 8349B prior to connecting or disconnecting the source module interface cable.

Connect the system as shown in Figure 2b-1.

FREQUENCY CONTROL

After the connections have been made, turn on the system instruments, and press **[INSTR PRESET]** on the HP 8350B. Allow the instruments to warm-up for 30 minutes. Next, enter a display multiplier on the HP 8350B so that the multiplied output frequency will be correctly displayed. A multiplication factor of six is entered by pressing:

[SHIFT] [START] [6] [MHz]

Once the multiplication factor is entered, you can now directly set the frequency range of interest on the HP 8350B front panel.

NOTE: Entering frequencies outside the 75.0 to 110.0 GHz (12.5 to 18.33 GHz) are invalid and the system will not work properly.

The multiplication factor may be reset to one by pressing:

[INSTR PRESET]

or by entering a multiplication factor of one by pressing:

[SHIFT] [START] [1] [MHz]

The multiplication factor may be "locked" by pressing:

[SHIFT] [ALT]

This eliminates having to re-enter the multiplication factor each time **INSTR PRESET** is pressed.

The lock may be removed and the multiplication factor may be reset to one by pressing:

[SHIFT] [INSTR PRESET]

POWER LEVEL CONTROL



Before performing any power level calibrations, ensure that the plug-in is not at maximum power.

The RF output power of the mm-wave source module is read on the HP 8349B display in this configuration. However, the output power level is controlled by the Power Level Control on the RF plug-in front panel. The power display of the HP 83592C/95C can be adjusted to match the display on the HP 8349B with the following steps:

Activate the **[EXT]** leveling key on the RF plug-in.

Set the power level of the HP 83592C/95C to 0 dBm using the rotary knob (plug-in) or keypad of the HP 8350B.

Set the frequency of the HP 8350B to a CW frequency within the desired frequency range.

Turn the **CAL** (Calibration adjustment) shown in Figure 2b-2 until the power output display of the HP 8349B reads 0 dBm.

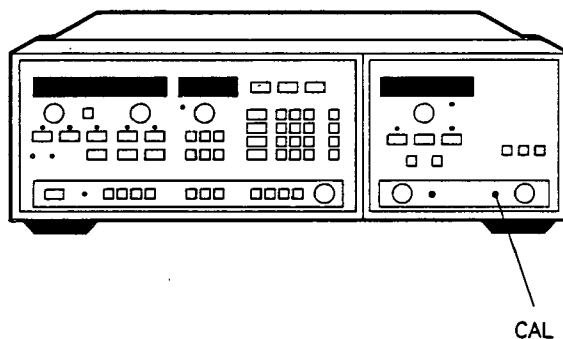

Figure 2b-2. HP 83592C/95C CAL Adjustment Location

POWER LEVELING

System Leveling

The source system configuration shown in Figure 2b-1, provides leveled source module output power with corrected power level flatness. With the EXT key on the RF plug-in active, a portion of the source module output power is coupled out of a directional coupler and detector internal to the source module. This signal is processed and fed through the HP 8349B DET OUT and connected to the RF plug-in external ALC input.

External Power Meter Leveling

Output power may also be leveled with a power meter and a directional coupler as shown in Figure 2b-3. Power meter leveling at the mm-wave source module output is possible using the power meters referenced in Table 1 (System General Information).

Set the plug-in ALC mode to [MTR]. For best accuracy, limit the sweep time to 100 seconds when this leveling method is used. A portion of the output power from the source module is coupled/detected and routed to the power meter. The DC voltage from the power meter recorder output is then applied to the RF plug-in external ALC input.

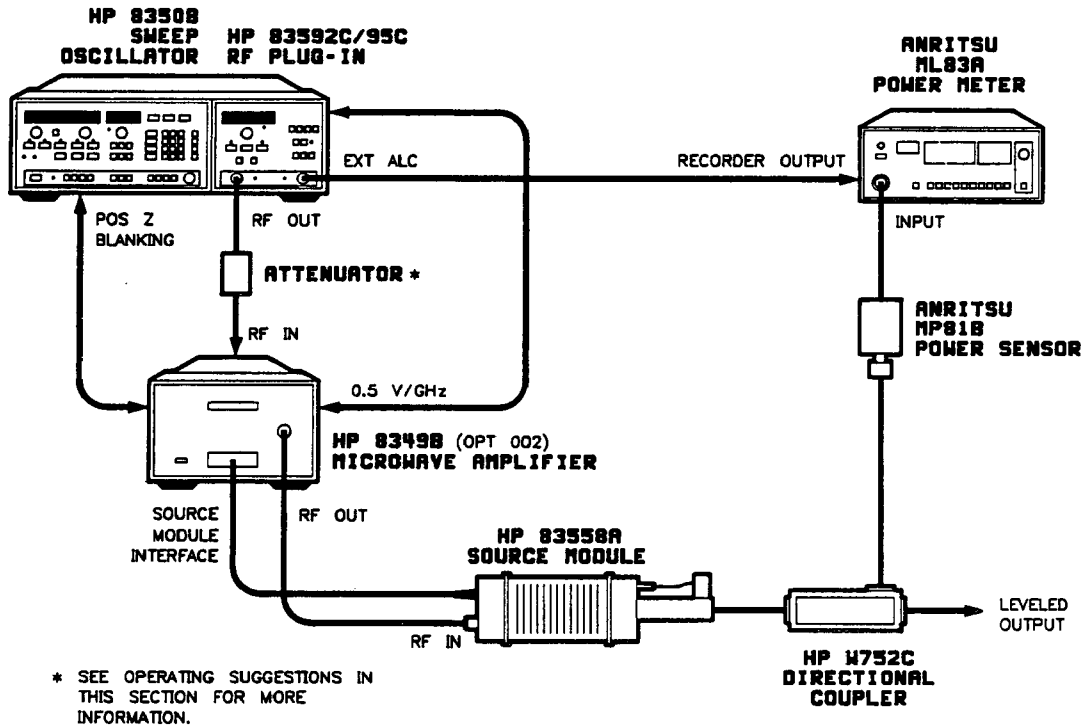

Figure 2b-3. External Power Meter Leveling at the HP 83558A Output

MODULATION

For complete specifications on all modulation modes described below, refer to Table 2b-1 (HP 83592C/95C/83558A System Specifications).

Frequency Modulation (FM INPUT Connector on HP 8350B)

The HP 83592C/95C/83558A system output signal can be frequency modulated using an external modulating signal applied to the HP 8350B rear panel FM INPUT connector.

The sensitivity and maximum deviations of the RF plug-in are multiplied by a factor of six because the HP 83558A source module multiplies the frequency by six. On the HP 83592C/95C, the sensitivity and coupling may be set via a configuration switch A3S1. The following configuration switch settings override the HP 8350 non-volatile memory settings at instrument preset. If the configuration switch settings are changed, you must press Instrument Preset again to load the memory with the new sensitivity and coupling settings.

The following is an example of the HP 83592C RF plug-in configuration switch settings. Refer to the specific RF plug-in operating and service manual for further details. The sensitivity setting for the overall system will be multiplied by six, -36MHz/V and -120MHz/V .

Description	A3S1 Switch Number	
	5	6
-6 MHz/V FM Sensitivity	1	1
-20 MHz/V FM Sensitivity	0	X
Direct-Coupled	*	0
Cross-over Coupled	X	1

NOTE: 1 = High
 0 = Low
 X = Don't Care
 When direct-coupled FM is selected (switch number 6), -20MHz/V is automatically selected.

Amplitude Modulation (AM INPUT Connector on HP 8350B)

On this source system configuration, the AM INPUT provides amplitude changes (up to approximately 5 dB) proportional to the modulating voltage. The sensitivity is typically 1 dB/V. The AM is typically limited to a frequency response of DC to 100 kHz.

Maximum depth of modulation can be achieved by starting at the maximum power and decreasing down to the minimum power level possible from the source module. For maximum modulation index, the HP 83558A source module should be set to a power level such that the peak of the modulation waveform does not exceed the maximum specified power level.

Pulse Modulation (PULSE IN Connector)

The application of a pulse or square wave signal to the PULSE IN connector provides a pulse or square wave modulated signal at the output of the HP 83558A. This input provides an ON/OFF power ratio of typically greater than 80 dB. The PULSE IN input is normally at a TTL HIGH (approximately +3 volts DC). When a TTL LOW signal (approximately 0 volts DC) is applied, the source module output signal is turned off.

With system leveled power, pulse repetition rates from 100 Hz to 500 kHz are achievable.

OPERATING SUGGESTIONS

When using an HP 83592C/95C as the source driver, you can optimize the ALC loop performance by using fixed attenuator(s). For example, typical HP 83592C/95C/83558A system power levels (not optimized) over the specified range, are as follows:

RF Plug-in (dBm)		HP 8349B (dBm)		HP 83558A (dBm)
Display	Output	Display	Output	Output
0	-14.0	0	+8.0	0
-5.0	-29.0	-5.0	-7.0	-5.0

The RF plug-in power output levels are quite low and can possibly reach the lower limit of the ALC modulator range. By adding a fixed attenuator(s) between the RF plug-in and the HP 8349B amplifier the overall system power level will decrease. A corresponding change in ALC drive signal will cause the RF plug-in to increase output power to correct for the apparent power loss. Thereby, avoiding ALC loop performance problems without overall system performance degradation.

Optimization of the system leveling loop is especially important in scalar network applications when square wave modulation is used. The square wave modulation performance of the RF plug-in is significantly better between maximum output power (depends upon which plug-in) and 15 db lower. By forcing an increase in power with an attenuator(s) the performance improvement is noticeable.

OPERATOR'S CHECK

DESCRIPTION

The following procedure will enable you to verify the proper operation of your HP 83592C/95C/83558A system by determining the system's output power and flatness performance over the W-band frequency range of 75.0 to 110.0 GHz at maximum leveled output power.

EQUIPMENT

Ensure that all the instruments below meet their own performance standards and have been recently calibrated to proper specifications before configuring them into the setup.

RF Signal Source	HP 8350B/HP 83592C/95C
Microwave Amplifier	HP 8349B
Power Meter	Anritsu ML83A
Power Sensor	Anritsu MP81B

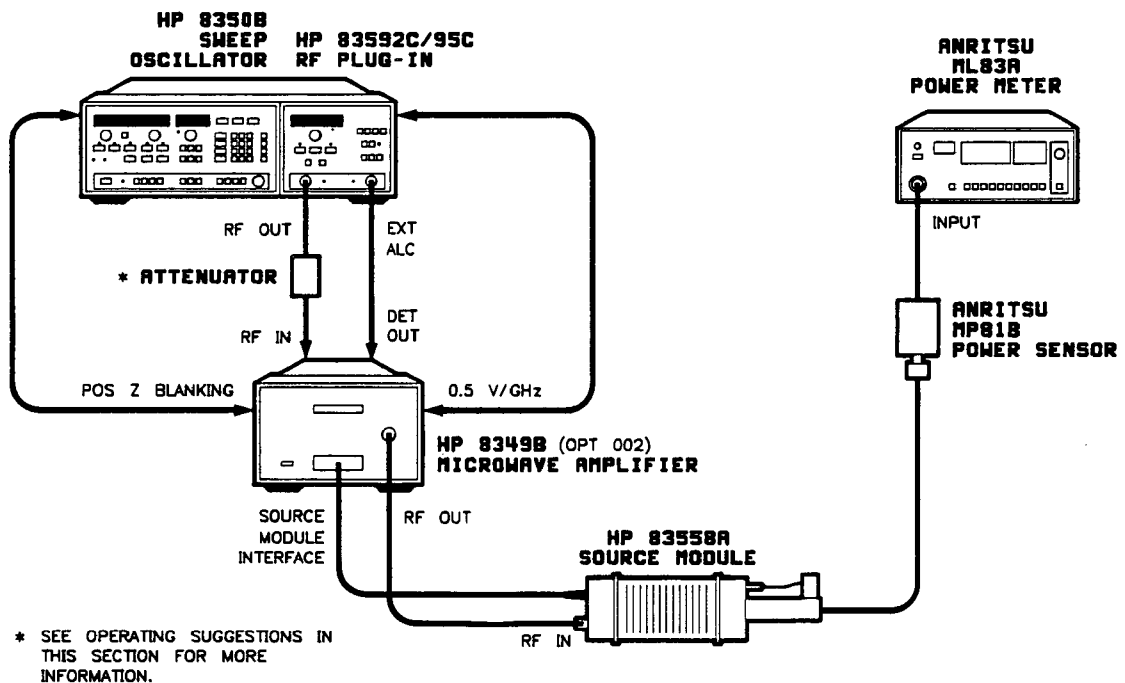

Figure 2b-4. System Configuration

PROCEDURE

1. Connect the equipment as shown in Figure 2b-4. Do not connect the power sensor to the HP 83558A output.



Turn off the AC power on the HP 8349B prior to connecting or disconnecting from the source module interface connector.

2. Turn on all system components.

3. On the power meter:

Press **[dBm]** mode.

Zero and calibrate the power meter. Set the CAL FACTOR at 100%. The CAL FACTOR will **not** be changed for the rest of the procedure. By leaving the CAL FACTOR set at 100% it ensures minimum specifications will be met.

4. On the HP 8350:

Press **[SHIFT] [INSTRUMENT PRESET]**

Press **[SHIFT] [START] [6] [MHz]**

Press **[SHIFT] [ALTr]**

Press **[START] [7] [5] [GHz]**

Press **[STOP] [1] [1] [0] [GHz]**

Press **[MAN] SWEEP** and adjust the FREQUENCY/TIME rotary knob for a 75.0 GHz frequency reading.

NOTE: Ensure that the **[MOD]** button is off or it will affect the power level indication on the power meter.

5. On the RF Plug-in:

Press **[EXT] ALC MODE** to put the system in the system leveled mode.

Press **[POWER LEVEL]**

Adjust the power level rotary knob for a 0 dBm reading on the RF plug-in display.

Connect the Anritsu MP81B power sensor to the HP 83558A output.

Adjust the RF plug-in EXT ALC CAL potentiometer for a 0 dBm reading on the power meter display. The displays of the RF plug-in, amplifier and power meter should all read 0 dBm (within the display tolerances).

6. On the HP 8350:

Find the minimum power point between 75.0 GHz and 110.0 GHz by slowly adjusting the FREQUENCY/TIME rotary knob from 75.0 GHz to 110.0 GHz and reading the power meter display. Note at what frequency the minimum power point occurs. See Figure 2b-5.



Figure 2b-5. Minimum Power Point (75.0 to 110.0 GHz)

Enter the frequency of the minimum power point by pressing [CW] XX.XX [GHz]

7. On the RF Plug-in:

Adjust the EXT ALC CAL potentiometer until the power meter display reads 0 dBm, thus ensuring the minimum power point is at maximum specified output power.

8. On the HP 8350:

Press [RECALL] [1]

Slowly adjust the FREQUENCY/TIME rotary knob from 75.0 to 110.0 GHz on the FREQUENCY/TIME display. Observe the power meter display through the entire manual sweep making sure that the power level displayed never exceeds 4.0 dBm. This ensures that from 75.0 to 110.0 GHz, the system's power flatness is within ± 2.0 dB of maximum leveled power, 0 dBm. See Figure 2b-6.

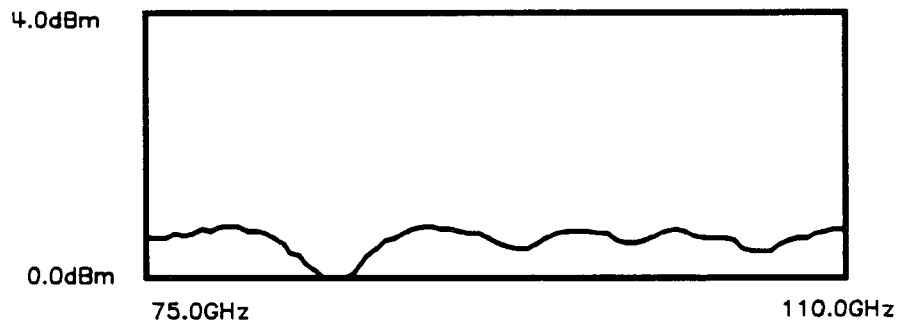

Figure 2b-6. Power Flatness Response (75.0 to 110.0 GHz)

NOTE: Ensure that the [MOD] button is off or it will affect the power level indication on the power meter.

This completes the Operator's Check. If your system fails this functional check refer to the paragraph titled TROUBLESHOOTING.

SYSTEM PERFORMANCE TESTS

INTRODUCTION

The procedures in this section test the performance of the HP 83592C/95C/83558A System using the specifications of Table 2b-1 as the performance standards. All tests can be performed without access to the interior of the instrument. The performance test procedures must be performed in the sequence given since some procedures rely on satisfactory test results in the foregoing steps. In order to fully verify the performance specifications of the HP 83558A, the performance tests in the Source Module Specifications and Service section must also be performed. None of the tests require access to the interior of the instrument.

Under the paragraph, TROUBLESHOOTING, you will find information on what to do if your system fails to meet specifications.

EQUIPMENT REQUIRED

Equipment required for the performance tests are listed in the Recommended Test Equipment tables under the tab Source System Guides, and Specifications and Service section of the manual. Any equipment that satisfies the critical specifications given in the table may be substituted for the recommended models. Ensure also that the test equipment used is currently calibrated to proper specifications.

NOTE: Use only the connectors and cables that are specified in the following test setups to ensure accurate test results.

OPERATION VERIFICATION

The Operation Verification consists of performing the source module specific performance tests (Source Module Specifications and Service Section) which include, Maximum Leveled Power (verifies frequency range), Power Flatness, and Power Level Accuracy. These tests provide reasonable assurance that the source module is functioning properly and will meet the needs of an incoming inspection (80% verification).

TEST RECORD

Results of the performance tests may be recorded in the Test Record at the end of the procedures. The Test Record lists all of the tested specifications and their acceptable limits. Test results recorded at incoming inspection can be used for comparison in periodic maintenance and troubleshooting or after repairs.

FREQUENCY CHARACTERISTICS

Range
Accuracy
CW Resolution
Stability

MODULATION CHARACTERISTICS

External FM

The performance tests listed above are source dependent and can be found in the Performance Tests of the HP83592C/95C Operating and Service manuals.

NOTE: When specifying the output frequency and modulation characteristics of the HP 83592C/95C/83558A system, all frequency specifications will be referenced from the sources used and must be multiplied by six because the HP 83558A multiplies the frequency by six. For special information about the multiplying components, refer to the "Theory of Operation" section found in the "Source Module Specifications and Service" section of this manual.

Table 2b-2. Performance Test Record Card

<p>HP 83592C/95C</p> <p>Serial Number _____ Date _____</p> <p>Humidity* _____ Tested By _____</p> <p>*(Optional) _____ Temperature* _____</p>				
Specification Tested	Test Conditions	Specification	Test Results	
			Pass	Fail
FREQUENCY				
Range ¹	_____	75.0 to 110.0 GHz ¹	_____	_____
Accuracy ¹	_____	± 60 MHz ¹	_____	_____
Resolution ¹	_____	156 kHz ¹	_____	_____
Stability ¹				
With Temperature, typically	_____	± 3.6 MHz/°C ¹	_____	_____
With 10% Line Voltage Change	_____	± 900 kHz ¹	_____	_____
With Time (in a 10 min period)	_____	< ± 1.8 GHz ¹	_____	_____
Residual FM, Peak (20 Hz to 15 kHz BW, CW Mode)	_____	< 54 kHz ¹	_____	_____
MODULATION				
External FM Maximum Deviations for Modulation				
Frequencies				
Crossover Coupled DC to 100 Hz	_____	± 450 MHz ¹	_____	_____
100 Hz to 1 MHz	_____	± 42 MHz ¹	_____	_____
1 MHz to 2 MHz	_____	± 30 MHz ¹	_____	_____
2 MHz to 10 MHz	_____	± 6 MHz ¹	_____	_____
Direct Coupled (— 80 MHz/V only) DC to 100 Hz	_____	± 72 MHz ¹	_____	_____
100 Hz to 1 MHz	_____	± 42 MHz ¹	_____	_____
1 MHz to 2 MHz	_____	± 30 MHz ¹	_____	_____
2 MHz to 10 MHz	_____	± 6 MHz ¹	_____	_____

1. These specifications are referenced from the appropriate HP 83590 Series RF plug-in manuals and have been multiplied by a factor of 6 because the HP 83558A multiplies the frequency by six.

TROUBLESHOOTING

Specification Failures

Failures are divided into two categories:

Category one describes systems that are meeting specifications in some areas, while failing others. If this is the case, do the following:

- Inspect the connectors and ensure that all connections are making good electrical contact.

- Inspect all cabling for breaks.

- Test again.

If your system is still failing at the SAME points, your instrument(s) or cable(s) could be defective and should be returned for repair. If, however, your system fails at DIFFERENT points, there is probably a loose connection or a mechanical failure somewhere in the setup.

Remember, it is possible the system may fail the test(s) because of measurement uncertainties. If you suspect this to be the case contact your nearest HP office for more information.

Category two failures are total specification failures. If your system fails any of these tests completely, do the following:

- Check the TEST SETUP for correct configuration of the instruments and connections.

- Inspect the connectors.

- Inspect the cables.

- Repeat the failed test(s).

If your system is still failing, the system is probably defective and needs repair.

Remember for the best accuracy in measurement, use only calibrated instruments.

**HP 8341B (Opt. 003)
Source System Guide**

TABLE of CONTENTS
HP 8341B (Opt. 003) SOURCE SYSTEM GUIDE

Introduction
System Specifications
Operation
Operator's Check
System Performance Tests
Introduction
Frequency Characteristics
Troubleshooting

Section 2c. HP 8341B (Opt. 003) Source System Guide

INTRODUCTION

This source system guide is intended to provide you with mm-wave system operating information for the HP 8341B (Opt. 003) synthesizer. It contains an operator's check, connection diagrams, system specifications, system performance tests, and system level troubleshooting. For detailed instructions regarding the operation or troubleshooting of the individual instruments, refer to the instrument's operating and service manual.

SYSTEM DESCRIPTION

The HP 8341B (Opt. 003) (10 MHz to 20 GHz) synthesized sweeper (hereafter referred to as HP 8341B) operates over the frequency range required by the HP 83558A millimeter-wave source module.

The HP 8341B synthesized sweeper combines with an HP 8349B microwave amplifier (with the built-in source module interface) to deliver the required 12.5 to 18.33 GHz input frequency and +17 dBm of output power for driving the HP 83558A source module.

NOTE: The HP 8341B synthesized sweeper requires a synthesizer interface cable for operation in a mm-wave system. This cable is included with the HP 83558A source module.

WARNING

This equipment is capable of radiating millimeter-wave energy from the end of unterminated waveguide. Do not look directly into the open end of any waveguide when it is connected to a source of millimeter-wave energy.

Take precautions consistent with ANSI C95.1 - 1982, a study performed by the American National Standards Institute that sets limits for human exposure to microwave and millimeter-wave energy. Copies of this publication are available from:

**American National Standards Institute
1430 Broadway
New York, N. Y. 10018**

SYSTEM SPECIFICATIONS

Table 2c-1 provides specifications for the HP 8341B synthesized sweeper/83558A system configuration. These are the performance standards against which the system is tested.

Table 2c-1. HP 8341B/83558A System Specifications

Frequency Characteristics	Modulation Characteristics
Range75.0 to 110.0 GHz Accuracy ¹ (25°C ± 5°C) CW ModeSame as time base Time Base ²Internal 10 MHz time base Aging rate: less than 1 x 10 ⁻⁹ /day and 2 x 10 ⁻⁷ /year after 30-day warmup. Temperature Effect: <1 x 10 ⁻¹⁰ /°C Line Voltage Effect: <1 x 10 ⁻¹¹ /±10%. All Sweep Modes (for sweep time > 100 msec) ³ ΔF ≤ (n) 30 MHz+1% of ΔF ± time base accuracy (n) 30 MHz ≥ ΔF ≤ 1800 MHz±2% of ΔF ΔF ≥ 1800 MHz±1% of ΔF or ±300 MHz, whichever is less n = harmonic band (1-4) of the HP 8341B CW Resolution18 Hz	External FM Bandwidth50 kHz to 10 MHz Deviationthe lesser of 60 MHz or 90 x fmod Sensitivity6 MHz/V or 60 MHz/V External AM Bandwidth, typicallyDC to 100 kHz Sensitivity, typically100%/V External Pulse Modulation Rise/Fall Time, typically50 ns Minimum RF Pulse Width System Leveled1 us On/off ratio, typically>80 dB Pulse Repetition Frequency System Leveled100 Hz to 500 kHz System Unleveled100 Hz to 5 MHz HP 8756A and 8757A AC Detection Mode CompatibilityYes

1. Specifications referenced are source driver specific (HP 8341B) and do not indicate the multiplying by six effect of the source module.
2. Overall accuracy of internal timebase is a function of timebase calibration ± aging rate ± temperature effects ± line effects.
3. After one hour warmup at selected CW frequency.

OPERATION

INTRODUCTION

This section is intended for operators familiar with the HP 8341B instruments. If you are unfamiliar with this system, refer to the Operator's check at the end of this section for more specific instructions.

In the operation instructions, any instrument setting or function key is defined by [] symbols around it.

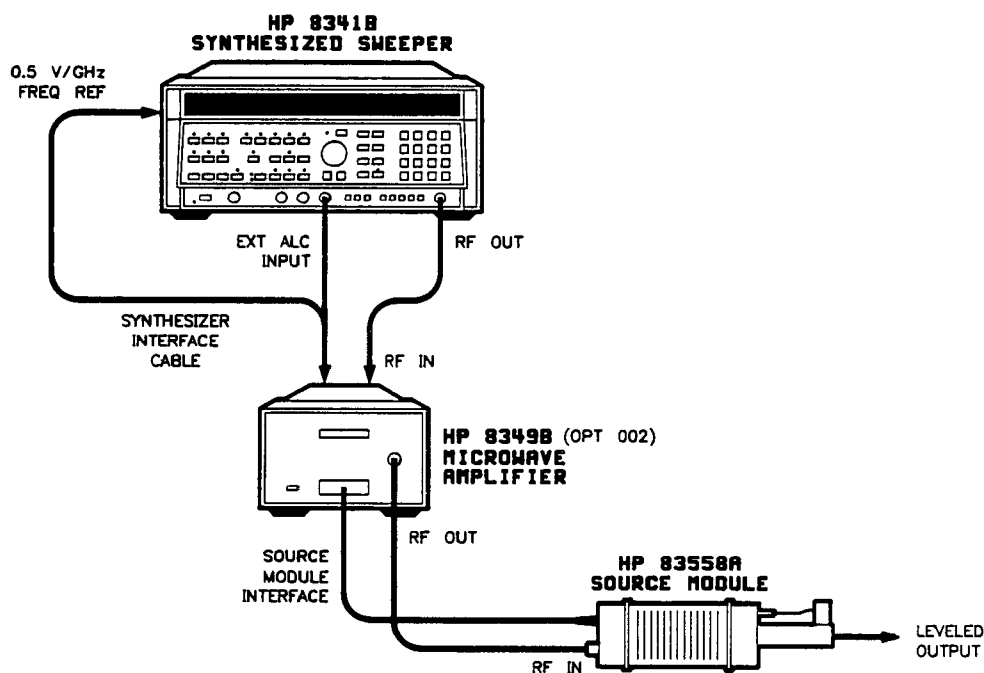

Figure 2c-1. HP 8341B/83558A Source System Configuration



Turn off the ac power on the HP 8349B prior to connecting or disconnecting the source module interface cable.

Connect the system as shown in Figure 2c-1.

FREQUENCY CONTROL

After the connections have been made, turn on the system, and press **[INSTR PRESET]** on the HP 8341B. Allow instruments to warm-up 30 minutes. Enter a display multiplier on the HP 8341B so that the multiplied output frequency will be correctly displayed. A multiplication factor of six should be entered by pressing:

[SHIFT] [START] [6] [Hz]

Once the multiplication factor is entered you can directly set the frequency range of interest on the HP 8341B front panel.

NOTE: Entering frequencies outside 75.0 to 110.0 GHz (12.5 to 18.33 GHz) are invalid and the system will not work properly.

The multiplication factor may be reset to one by pressing:

[INSTR PRESET]

or by entering a multiplication factor of one by pressing:

[SHIFT] [START] [1] [Hz]

The multiplication factor may be "locked" by pressing:

[SHIFT] [ALT]

This eliminates having to re-enter the multiplication factor each time INSTR PRESET is pressed.

The lock may be removed and the multiplication factor may be reset to one by pressing:

[SHIFT] [INSTR PRESET]

POWER LEVEL CONTROL



Before performing any power level calibrations, ensure that the HP 8341B synthesizer is not at maximum power.

Power is controlled by pressing **[POWER LEVEL]**. The step keys, rotary knob, or keypad controls the output power from the synthesizer. The actual output power from the mm-wave source module is read on the HP 8341B PWR dBm display in the system leveled mode. To activate system leveling, **[SHIFT] [XTAL]**. Once activated, the display will read "EXT MODULE POWER: - XX.XX dBm" and the internal attenuator is automatically set at 0 dB. The HP 8341B internal attenuator is controlled by pressing **[SHIFT] [SLOPE]** and should normally be set to 0 dB.

POWER LEVELING

System Leveling

System leveling provides calibrated, flat power from the output of the mm-wave source module. The HP 8341B/83558A configuration shown in Figure 2c-1 provides leveled source module output power with corrected power level flatness. With the **[SHIFT] [XTAL]** keys on, a portion of the source module power output is coupled out of a directional coupler and detector internal to the source module. This signal is processed and fed through the HP 8349B synthesizer interface and applied to the HP 8341B ALC circuit.

External Power Meter Leveling

Output power may also be leveled with a power meter and a directional coupler as shown in Figure 2c-2. Power meter leveling at the source module output is possible using the power meters referenced in Table 1-1 (System General Information).

Set the ALC mode to **[METER]** on the HP 8341B. The sweep time is limited to 100 seconds when this leveling method is used. A portion of the mm-wave output signal from the source module is coupled/detected and routed to the power meter. The DC voltage from the power meter recorder output is then applied to the HP 8341B external ALC circuit.

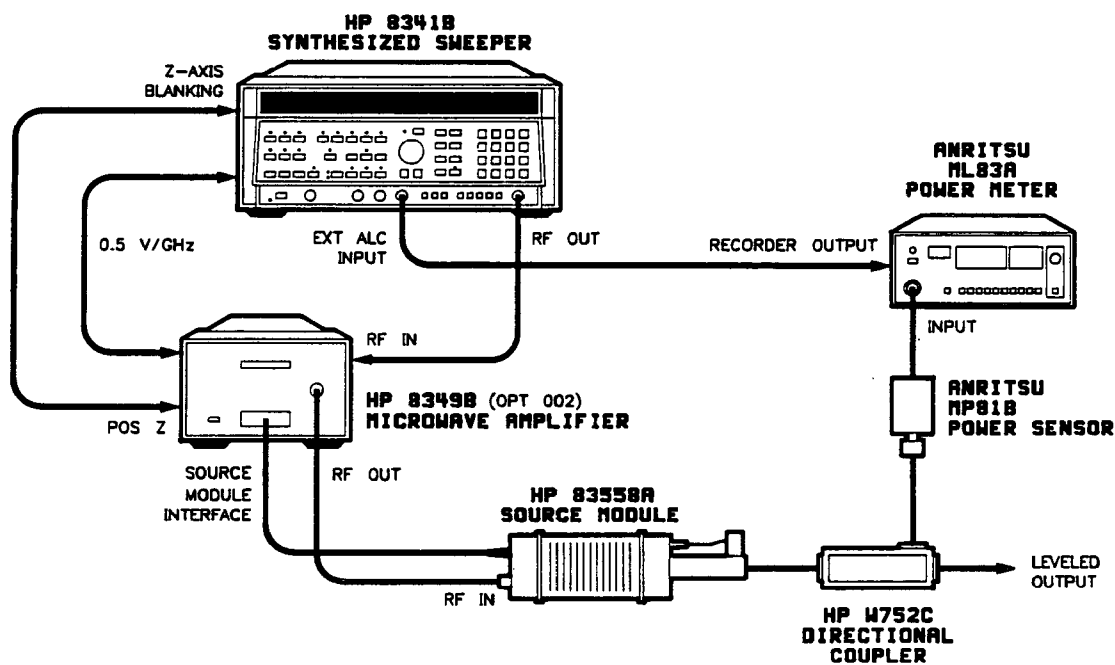

Figure 2c-2. External Power Meter Leveling at the HP 83558A Source Module Output

MODULATION

For complete specifications on all modulation modes described below, refer to Table 2c-1 (HP 8341B/83558A System Specifications).

Frequency Modulation (FM Connector on HP 8341B)

With the FM key activated, the source module may be frequency modulated from an external input signal. The FM deviation is multiplied by six by the HP 83558A source module but the displayed FM sensitivity remains correct as long as the frequency multiplication factor remains at six.

FM sensitivities of 2 MHz/V or 20 MHz/V are available over a bandwidth of 50 KHz to 10 MHz.

Amplitude Modulation (AM Connector on HP 8341B)

When the AM key is activated, the AM input is used for linear, DC-coupled amplitude modulation. The small signal -3 dB bandwidth extends from DC to 100 kHz.

The sensitivity is 100% per volt. This means that $+1.0$ volt doubles the output voltage ($+6$ dB), while -1.0 volt shuts the output completely off.

For maximum modulation index, the HP 83558A source module should be set to a power level 3 dB below maximum power (note that 3 dB power is 6 dB volts).

Pulse Modulation (PULSE Connector on HP 8341B)

With the PULSE key activated, and the HP 8341B internally leveled, the application of a pulsed or square wave signal to the PULSE connector provides a pulsed or square wave modulated signal at the output of the HP 83558A. This input provides an ON/OFF power ratio of greater than 80 dB. The PULSE IN input is normally at a TTL HIGH (approximately +3 volts DC). When a TTL LOW signal (approximately 0 volts DC) is applied, the mm-wave output signal is turned off.

OPERATING SUGGESTIONS

When using an HP 8341B synthesizer as the source driver, you can optimize the ALC loop performance by using fixed attenuator(s). For example, typical HP 8341B/83558A system power levels (not optimized) over the specified range, are as follows:

SYNTHESIZER (dBm)		HP 83558A (dBm)
DISPLAY	OUTPUT	OUTPUT
0	-14.0	0
-5.0	-29.0	-5.0

The RF synthesizer power output levels are quite low and can possibly reach the lower limit of the ALC modulator range. By adding a fixed attenuator(s) between the RF synthesizer and the HP 8349B amplifier, the overall system power level will decrease. A corresponding change in ALC drive signal will cause the RF synthesizer to increase output power to correct for the apparent power loss and thereby operate at a more desirable ALC level.

OPERATOR'S CHECK

DESCRIPTION

The following procedure will enable you to verify the proper operation of your HP 8341B/83558A system by determining the system's output power and flatness performance over the W-band frequency range of 75.0 to 110.0 GHz at maximum leveled output power.

EQUIPMENT

Ensure that all the instruments below meet their own performance standards and have been recently calibrated to proper specifications before configuring them into the setup.

- RF Signal Source HP 8341B Synthesized Sweeper
- Microwave Amplifier HP 8349B
- Power Meter Anritsu ML83A
- Power Sensor Anritsu MP81B

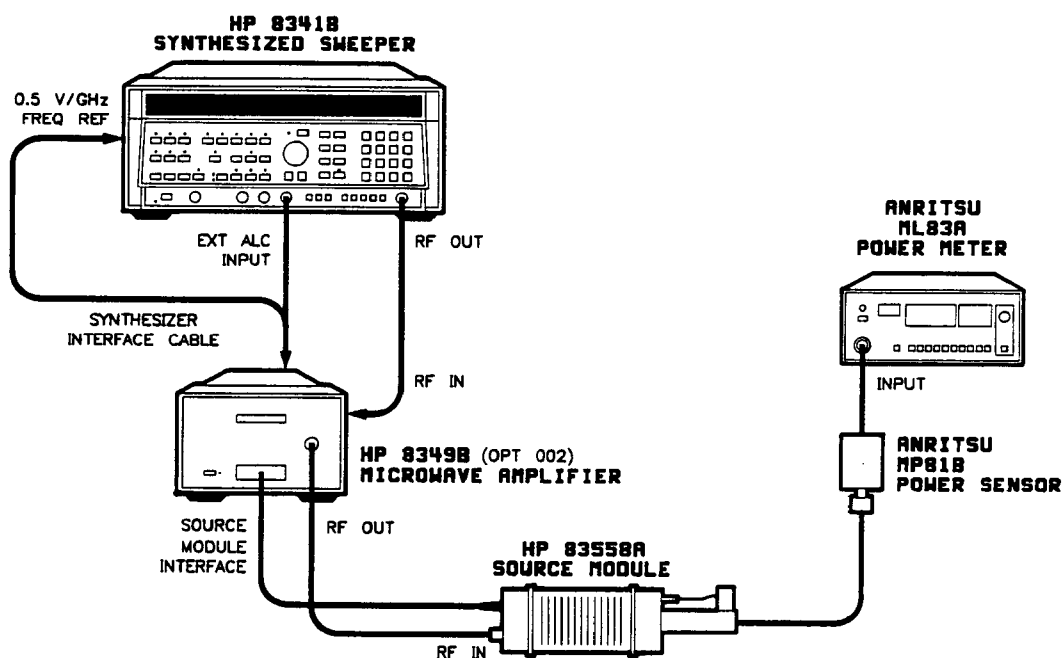

Figure 2c-3. System Configuration

PROCEDURE

1. Connect the equipment as shown in Figure 2c-3. Do not connect the power sensor to the HP 83558A output.



Turn off the AC power on the HP 8349B prior to connecting or disconnecting from the source module interface connector.

2. Turn on all system components.

3. On the power meter:

Press [dBm] mode.

Zero and calibrate the power meter. Set the CAL FACTOR at 100%. The CAL FACTOR will not be changed for the rest of the procedure. By leaving the CAL FACTOR at 100%, it ensures minimum specifications will be met.

4. On the HP 8341B:

Press [SHIFT] [INSTR PRESET]

Press [SHIFT] [START] [6] [Hz]

Press [SHIFT] [ALT]

Press [SHIFT] [XTAL] EXT INPUT leveling

Press [CW] [7] [5] [GHz]

Connect the power sensor to the HP 83558A output.

Press [POWER LEVEL] and adjust rotary knob for a 0 dBm reading on the power meter display. Ensure that the power meter display is within 2.00 dB of the HP 8349B display.

NOTE: Ensure that the [AM MOD] button is in the **off** state or it will affect the accuracy of this test.

5. Press [CW]

While observing the power meter display, find the minimum power point between 75.0 to 110.0 GHz by slowly adjusting the rotary knob. Note at what frequency the minimum power point is. See Figure 2c-4.

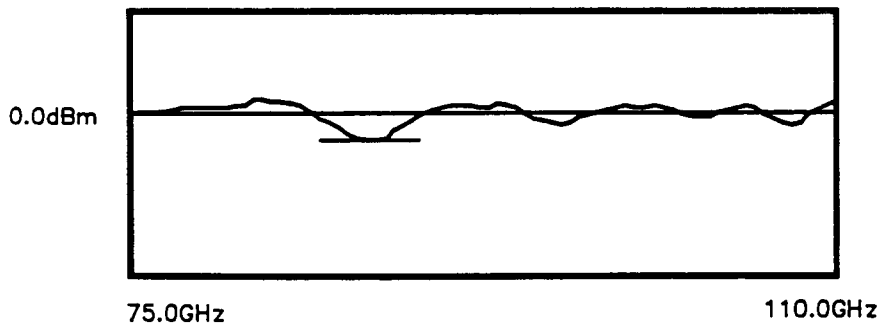

Figure 2c-4. Minimum Power Point (75.0 to 110.0 GHz)

Enter the frequency at the minimum power point by pressing [CW] XX.XX [GHz]

6. Press **[POWER LEVEL]** and adjust the rotary knob until you obtain a 0 dBm reading on the power meter display.
7. Press **[CW] [7] [5] [GHz]**

Tune the rotary knob from 75.0 to 110.0 GHz and ensure that the power level displayed on the power meter never exceeds 4.0 dBm. This ensures that from 75.0 to 110.0 GHz, the system's power flatness is within ± 2.0 dB of maximum leveled power, 0 dBm. See Figure 2c-5.

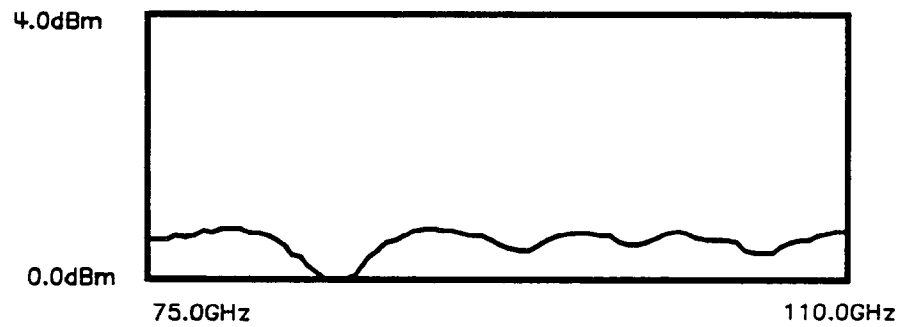

Figure 2c-5. Power Flatness Response (75.0 to 110.0 GHz)

This completes the Operator's Check. If your system fails this functional check, refer to the paragraph titled TROUBLESHOOTING.

SYSTEM PERFORMANCE TESTS

INTRODUCTION

The procedures in this section test the performance of the HP 8341B/83558A source system using the specifications of Table 2c-1 as the performance standards. All tests can be performed without access to the interior of the instrument. The performance test procedures must be performed in the sequence given since some procedures rely on satisfactory test results in the foregoing steps. In order to fully verify the performance specifications of the HP 83558A, the performance tests in the Source Module Specifications and Service Section must also be performed. None of the tests require access to the interior of the instrument.

Under the paragraph, TROUBLESHOOTING, you will find information on what to do if your system fails to meet specifications.

EQUIPMENT REQUIRED

Equipment required for the performance tests are listed in the Recommended Test Equipment tables under the tabs Source System Guides, and Source Module Specifications and Service. Any equipment that satisfies the critical specifications given in the table may be substituted for the recommended models. Ensure also that the test equipment used is currently calibrated to proper specifications.

NOTE: Use only the connectors and cables that are specified in the following test setups to ensure accurate test results.

OPERATION VERIFICATION

The Operation Verification consists of performing the source module specific performance tests (Source Module Specifications and Service Section) which include, Maximum Leveled Power (verifies frequency range), Power Flatness, and Power Level Accuracy. These tests provide reasonable assurance that the source module is functioning properly and should meet the needs of an incoming inspection (80% verification).

TEST RECORD

Results of the performance tests may be recorded in the Test Record at the end of the procedures. The Test Record lists all of the tested specifications and their acceptable limits. Test results recorded at incoming inspection can be used for comparison in periodic maintenance and troubleshooting or after repairs.

FREQUENCY CHARACTERISTICS

Range
Accuracy
Resolution
Stability

The performance tests listed above are source dependent and can be found under the following performance tests in the appropriate HP 8341B synthesized sweeper Operating and Service manual.

NOTE: When specifying the output frequency and modulation characteristics of the HP 8341B/83558A system, all frequency specifications are referenced from the sources used and must be multiplied by six because the HP 83558A multiplies the frequency by six. For special information about the multiplying components, refer to the "Theory of Operation" section found in the "Source Module Specifications and Service" section of this manual.

Table 2c-2. Performance Test Record

HP 8341B (Opt. 003) System				
Serial Number _____		Date _____		
Humidity* _____		Tested By _____		
(Optional)		Temperature _____		
Specifications Tested	Test Conditions	Specification	Test Results	
FREQUENCY				
Range ¹	_____	75.0 to 110.0 GHz ¹	_____	_____
Accuracy (25°C ± 5°C)	_____		_____	_____
CW Mode	_____	Same as time base	_____	_____
Time Base	_____	Internal 10 MHz time base Aging rate: less than 1 x 10 ⁻⁹ /day and 2 x 10 ⁻⁷ /year after 30-day warmup.	_____	_____
	_____	Temperature effect < 1 x 10 ⁻¹⁰ /°C	_____	_____
	_____	Line Voltage effect < 1 x 10 ⁻¹¹ /± 10%	_____	_____
All Sweep Modes (for sweep time > 100 msec)	_____	ΔF ≤ (n) 30 MHz ± 1% of ΔF ± time base accuracy (n) 30 MHz < ΔF ≤ (n) 600 MHz: ± 2% of ΔF ΔF ≥ (n) 600 MHz: ± 1% of ΔF or ± 300 MHz whichever is less n = harmonic band (1-4) of the HP 8341B	_____	_____
CW Resolution ¹	_____	18 Hz	_____	_____

1. These specifications are referenced from the HP 8341B synthesized sweeper manuals and have been multiplied by a factor of 6 because the HP 83558A multiplies the frequency by 6.

TROUBLESHOOTING

Specification Failures

Failures are divided into two categories:

Category one describes systems that are meeting specifications in some areas, while failing in others. If this is the case, do the following:

- Inspect the connectors and ensure that all connections are making good electrical contact.

- Inspect all cabling for breaks.

- Test again.

If your system is still failing at the SAME points, your instrument(s) or cable(s) could be defective and should be returned for repair. If, however, your system fails at DIFFERENT points, there is probably a loose connection or a mechanical failure somewhere in the setup.

Remember, it is possible the system may fail the performance test(s) because of measurement uncertainties. If you suspect this to be the case, contact your nearest HP office for more information.

Category two failures are total specification failures. If your system fails any of these tests completely, do the following:

- Check the TEST SETUP for correct configuration of the instruments and connections.

- Inspect the connectors.

- Inspect the cables.

- Repeat the failed test(s).

If your system is still failing, the system is probably defective and needs repair.

Also, for the best accuracy in measurement, use only calibrated instruments.

**HP 8673C/D
Source System Guide**

TABLE of CONTENTS
HP 8673C/D SOURCE SYSTEM GUIDE

Introduction
System Specifications
Operation
Operator's Check
System Performance Tests
Introduction
Frequency Characteristics
Troubleshooting

Section 2d. HP 8673C/D Source System Guide

INTRODUCTION

This source system guide is intended to provide you millimeter-wave system operating information for the HP 8673C/D series synthesized signal generators (unless otherwise stated will be hereafter referred to as the HP 8673C/D). It contains an Operator's Check, connection diagrams, system specifications, system performance tests, and system level troubleshooting. For detailed instruction regarding the operation or troubleshooting of the individual instruments, refer to the instrument's operating and service manual.

SYSTEM DESCRIPTION

HP 8673C/D synthesized signal generators provide direct, factory calibrated control and display of system output frequency and level. HP 8673C/D synthesized signal generators with serial number prefix 2552A are fully compatible for use with a millimeter-wave system consisting of an HP 8349B microwave amplifier and an HP 83558A millimeter-wave source module. For proper display accuracy, leveling flatness, and harmonic suppression, the 1.0V/GHz output on your HP 8673C/D will have to be modified for a 0.5V/GHz output. Serial number prefixes previous to 2552A will require the modification for proper system operation. A retrofit kit may be ordered to implement these modifications. Refer to the table below to determine the retrofit kit number applicable to the system synthesizer. For detailed information concerning synthesizer operation, refer to the HP 8673C/D Operating and Service Manual.

Synthesizer	Retrofit Kit Part Number
HP 8673C	08673-60182
HP 8673D	08673-60183

NOTE: The HP 8673C/D synthesized signal generators require a synthesizer interface cable for operation in a mm-wave system. The cable is available as HP Part No. 5061-5391.

WARNING

This equipment is capable of radiating millimeter-wave energy from the end of unterminated waveguide. Do not look directly into the open end of any waveguide when it is connected to a source of millimeter-wave energy.

Take precautions consistent with ANSI C95.1 - 1982, a study performed by the American National Standards Institute that sets limits for human exposure to microwave and millimeter-wave energy. Copies of this publication are available from:

**American National Standards Institute
1430 Broadway
New York, N. Y. 10018**

SYSTEM SPECIFICATIONS

Table 2d-1 provides specifications for the HP 8673C/D/synthesized signal generator/83558A system configuration. These are the performance standards against which the system is tested.

Table 2d-1. 8673C/D/83558A System Specifications

<p>Frequency Characteristics</p> <p>Range 8673C/D 75.0 to 110.0 GHz</p> <p>Accuracy¹ (25°C ± 5°C) CW Mode Same as time base Time Base² Internal 10 MHz time base Aging rate less than 5x10⁻¹⁰/day after a 24-hour warmup. Temperature effect: <1x10⁻¹⁰/°C Line Voltage effect: <5x10⁻¹⁰/+5% to -10% All Sweep modes¹ (for sweep time > 100 ms)³ Same as time base. CW Resolution 18 kHz</p> <p>Modulation Characteristics</p> <p>External FM Maximum Deviations for Modulation Frequencies 100 Hz to 10 MHz (60,200 kHz/V ranges) 1 kHz to 10 MHz (600 kHz/V, 2,6,20 MHz/V ranges) The smaller of 60 MHz or fmod x 120</p>	<p>Modulation Characteristics (Cont'd)</p> <p>Sensitivity FM Mode, typically 240, 600, 1800 kHz/V and 1, 18, 60 MHz/V</p> <p>External AM Bandwidth, typically DC to 80 kHz Sensitivity, typically 30%/V and 100%/V</p> <p>External Pulse Modulation Rise/Fall Time, typically 40 ns Minimum RF Pulse Width System Leveled, typically 1 us On/Off Ratio, typically > 80 dB Pulse Repetition Frequency System Leveled, typically 50 Hz to 100 kHz System Unleveled, typically ... 50 Hz to 500 kHz HP 8756A and HP 8757A AC Detection Mode Compatibility Yes</p>
--	--

1. Specifications referenced are source driver specific (HP 8673C/D) and do not indicate the multiplying by six effect of the source module.
2. Overall accuracy of internal timebase is a function of timebase calibration ± aging rate ± temperature effects ± line effects.
3. After one hour warmup at selected CW frequency.

OPERATION

INTRODUCTION

This section is intended for operators familiar with the HP 8673C/D instruments. If you are unfamiliar with this system, refer to the Operator's check at the end of this section for more specific instructions.

In the operation instructions, any instrument setting or function key is defined by [] symbols around it.

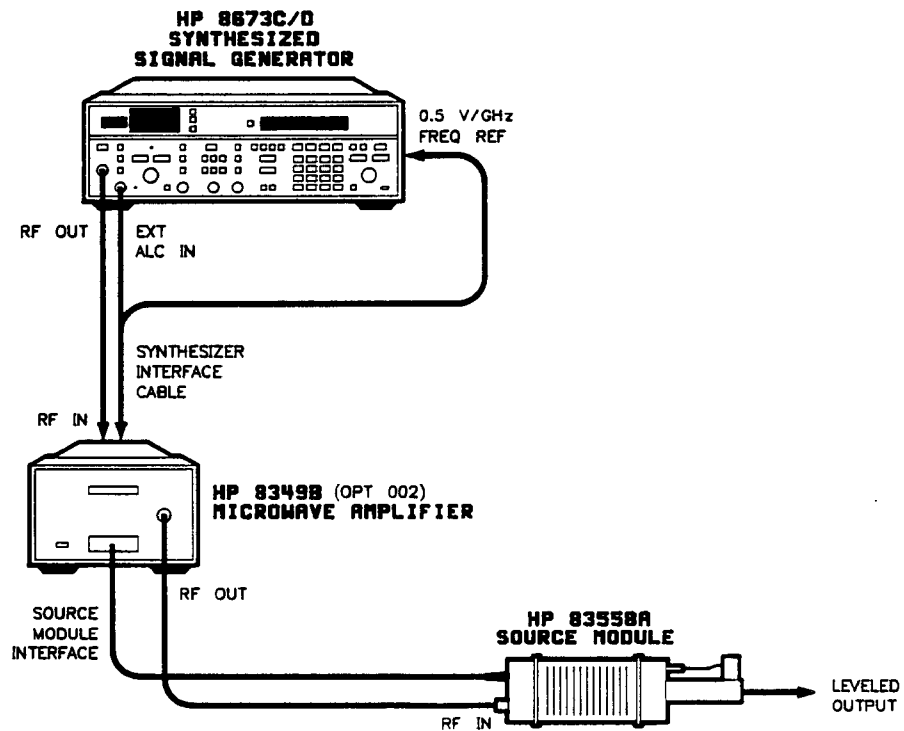

Figure 2d-1. HP 8673C/D/83558A Source System Configuration



Turn off the ac power on the HP 8349B prior to connecting or disconnecting the source module interface cable.

Connect the system as shown in Figure 2d-1.

FREQUENCY CONTROL

After the connections have been made, turn on the system. Allow instruments to warm-up 30 minutes. The synthesizer allows the user to enter and display the actual frequency of the output of the system by entering a multiplication factor into the synthesizer front panel. Preset the synthesizer by pressing:

[RCL] [BACKSPACE]

Enter the multiplication factor by pressing:

[SHIFT] [MULT] [6] [XFREQ]

The actual system output frequency is now shown on the synthesizer display. Once the multiplication factor is entered, the system output frequency can be controlled directly using the synthesizer. The multiplication factor can be reset to one by pressing:

[SHIFT] [MULT] [1] [XFREQ]

POWER LEVEL CONTROL



Before performing any power level calibrations, ensure that the HP 8673C/D synthesizer is not at maximum power.

The system output power can be entered, displayed, and controlled directly with the synthesizer. Power level can be controlled by activating the ALC DIODE key and adjusting the OUTPUT LEVEL VERNIER knob.

POWER LEVELING

System Leveling

To activate system leveling mode, connect the equipment as shown in Figure 2d-1 and press:

[SHIFT] [DIODE/SYS]

NOTE: When using system leveling mode, use only the +20, +10, or 0 dBm range when setting system output level.

When in system leveling mode, both the DIODE/SYS key and the INTERNAL ALC key will light. The power output of the system is detected in the millimeter-wave source module. The detected signal is fed back to the HP 8349B which converts it to a voltage that is proportional to the system output power in volts per dB. This voltage is fed back to the synthesizer through the EXT ALC IN connector. Power level corrections are made by the synthesizer. The actual system output power is shown on the synthesizer display. System output power can also be remotely programmed and read over HP-IB.

External Power Meter Leveling

This power leveling method has a slow settling time but has the advantage of high sensitivity and temperature compensation. Figure 2d-2 illustrates a typical external power meter leveling setup.

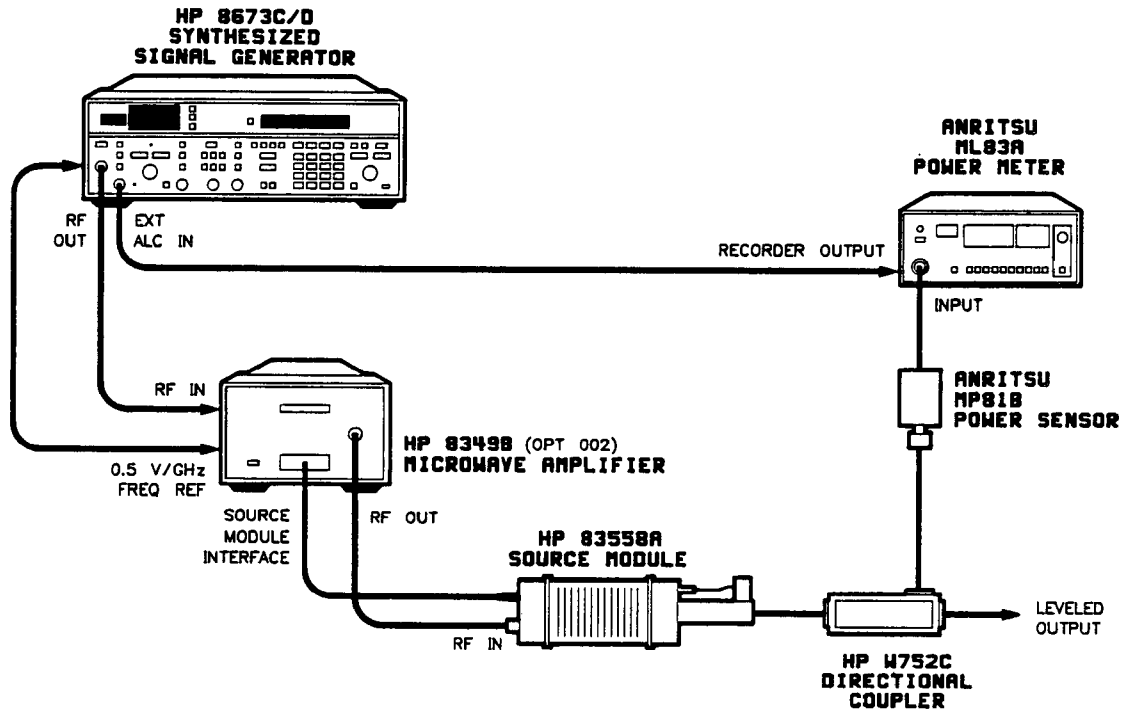

Figure 2d-2. External Power Meter at the HP 83558A Source Module Output.

To activate the external power meter leveling mode, connect the equipment as shown in Figure 2d-2 and press the **[PWR MTR]** key on the HP 8673C/D front panel. The output of the millimeter-wave source module is detected by the power meter. A linearly proportional voltage is fed back to the synthesizer through the **EXT ALC IN** connector on the front panel. Power level corrections are made by the synthesizer. The actual system output power is shown on the microwave amplifier display. The synthesizer output level meter can be calibrated to the microwave amplifier display by adjusting the **CAL** control on the synthesizer front panel. Set **[RANGE]** to 0 dBm and the **[VERNIER]** to 0 dBm. Adjust the **[CAL]** control for a system output level of 0 dBm as indicated on the microwave amplifier display.

MODULATION

For complete specifications on all modulation modes described below, refer to Table 2d-1.

Frequency Modulation

The millimeter-wave system's output signal can be frequency modulated by applying an external modulating signal to the synthesizer **FM IN** connector. FM deviation range is chosen by the **FM DEVIATION MHz** keys on the synthesizer front panel. The amount of deviation varies linearly with the input signal level; 1 volt peak develops full scale modulation. Due to the frequency multiplication of the millimeter-wave source module, the sensitivity and maximum deviation of the synthesizer is multiplied by a factor of six. See Table 2d-2.

Table 2d-2. Synthesizer and System Sensitivities

Sensitivity of Synthesizer	Sensitivity of System
30, 100, 300 kHz per volt 1, 3, 10 MHz per volt	180, 600, 1800 kHz per volt 6, 18, 60 MHz per volt

Amplitude Modulation

The millimeter-wave system's output signal can be amplitude modulated by applying an external modulating signal to the synthesizer AM IN connector. The modulation range is selected using the AM keys on the synthesizer front panel. The depth of modulation varies linearly with the input signal; 1 volt peak develops full scale modulation. The AM bandwidth extends from DC to 100 kHz.

Pulse Modulation

The source module's output signal can be pulse modulated by applying a TTL compatible pulse waveform to the PULSE IN connector on the synthesizer front panel. This input provides an on/off power ratio of greater than 80 dB at the system output. The PULSE IN input is normally at a TTL high (approximately +3 volts DC). When a TTL low signal (approximately 0 volts DC) is applied, the source module's output signal is turned off. Leveled pulse repetition rates from 50 Hz to 100 kHz are achievable in system leveling mode with pulse widths as narrow as 1 microsecond. Level accuracy is comparable to CW accuracy down to 5 microsecond pulse widths.

OPERATOR'S CHECK

DESCRIPTION

This procedure allows verification of proper operation of the millimeter-wave system by determining the system's output power and flatness performance at maximum leveled output power over the entire frequency range.

EQUIPMENT

Ensure that all the instruments listed below meet their own performance standards and have recently been calibrated to proper specifications before configuring them into the test setup.

RF Signal Source	HP 8673C/D Synthesized Signal Generator
Microwave Amplifier	HP 8349B
Power Meter	Anritsu ML83A
Power Sensor	Anritsu MP81B

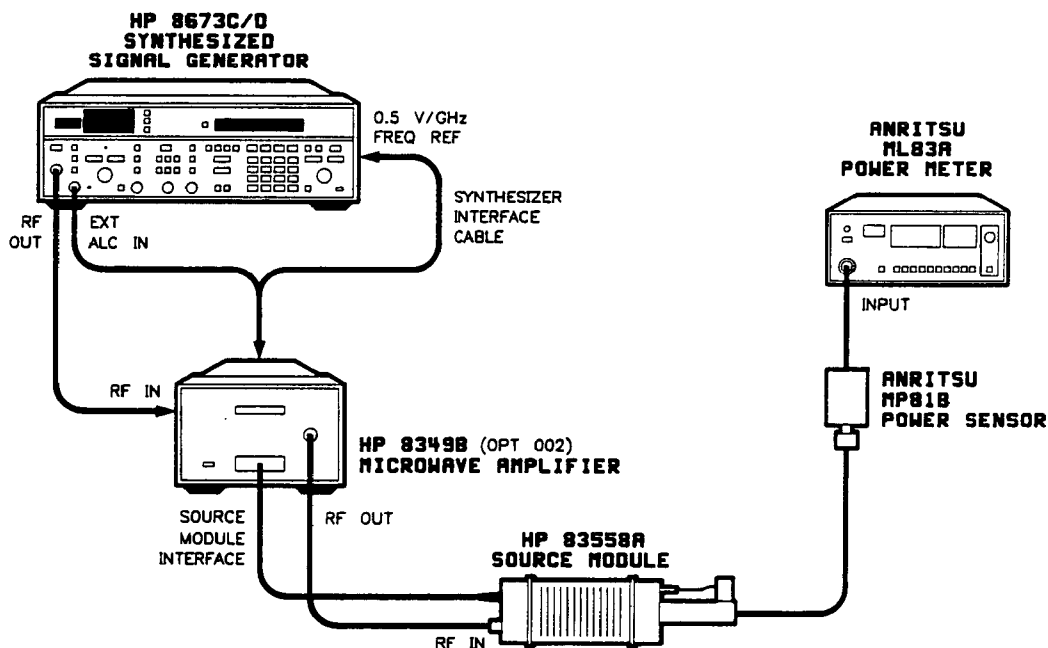

Figure 2d-3. System Configuration

PROCEDURE

1. Connect the equipment as shown in Figure 2d-3. Do not connect the power sensor to the HP 83558A output.



Turn off the ac power on the HP 8349B prior to connecting or disconnecting the source module interface connector. Before performing any power level calibrations, ensure that the HP 8673C/D synthesizer is not at maximum power.

2. Turn on all system components.
3. On the power meter:

Press [dBm] mode.

Zero and calibrate the power meter. Set the CAL FACTOR at 100%. The CAL FACTOR will not be changed for the rest of the procedure. By leaving the CAL FACTOR at 100%, it ensures minimum specifications will be met.

4. On the HP 8673C/D:

Press [SHIFT] [MULT] [6] [xFREQ]

Press SWEEP FREQ [START] [7] [5] [.] [0] [GHz]

Press SWEEP FREQ [STOP] [1] [1] [0] [.] [0] [GHz]

Press SWEEP RATE [STEP] [2] [0] [0] [MHz]

Press SWEEP MODE [MANUAL]

Press RANGE [▲] for a +10 dBm reading on the RANGE dBm display.

5. Adjust the synthesizer VERNIER for a reading of 0 dBm on the power meter.
6. Find the minimum power point between 75.0 GHz and 110.0 GHz by slowly adjusting the TUNE knob from 75.0 GHz to 110.0 GHz and noting at which frequency minimum power occurs. See Figure 2d-4.



Figure 2d-4. Minimum Power Point (75.0 to 110.0 GHz)

7. Tune the frequency to the minimum power point.
8. Adjust the VERNIER until the power meter display reads 0 dBm.
9. Tune the synthesizer frequency to 75.0 GHz.
10. Slowly tune the frequency from 75.0 GHz to 110.0 GHz while watching the power level readings on the power meter. The power level displayed should not exceed +4.0 dBm. See Figure 2d-5.

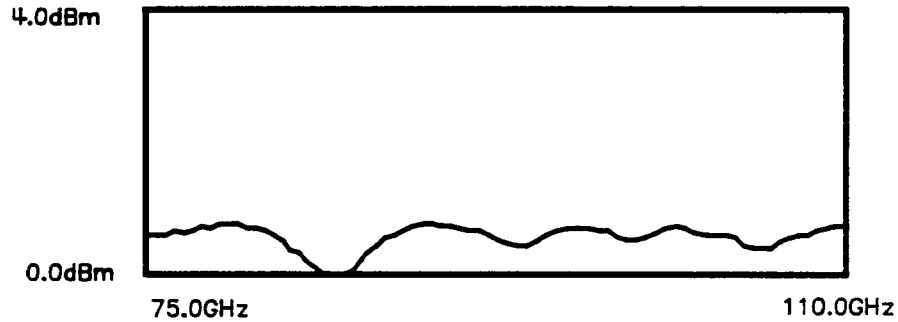

Figure 2d-5. Power Flatness Response (75.0 to 110.0 GHz)

This completes the Operator's Check. If your system fails this functional check, refer to the paragraph titled TROUBLESHOOTING.

SYSTEM PERFORMANCE TESTS

INTRODUCTION

The procedures in this section test the performance of the HP 8673C/D/83558A source system using the specifications of Table 2d-1 as the performance standards. All tests can be performed without access to the interior of the instrument. The performance test procedures must be performed in the sequence given since some procedures rely on satisfactory test results in the foregoing steps. In order to fully verify the performance specifications of the HP 83558A, the performance tests in the Source Module Specifications and Service Section must also be performed. None of the tests require access to the interior of the instrument.

Under the paragraph, TROUBLESHOOTING, you will find information on what to do if your system fails to meet specifications.

EQUIPMENT REQUIRED

Equipment required for the performance tests are listed in the Recommended Test Equipment tables in the Source System Guides, and Specifications and Service Sections of the manual. Any equipment that satisfies the critical specifications given in the table may be substituted for the recommended models. Ensure also that the test equipment used is currently calibrated to proper specifications.

NOTE: Use only the connectors and cables that are specified in the following test setups to ensure accurate test results.

OPERATION VERIFICATION

The Operation Verification consists of performing the source module specific performance tests (Source Module Specifications and Service Section) which include, Maximum Leveled Power (verifies frequency range), Power Flatness, and Power Level Accuracy. These tests provide reasonable assurance that the Source Module is functioning properly and should meet the needs of an incoming inspection (80% verification).

TEST RECORD

Results of the performance tests may be recorded in the Test Record at the end of the procedures. The Test Record lists all of the tested specifications and their acceptable limits. Test results recorded at incoming inspection can be used for comparison in periodic maintenance and troubleshooting and after repairs or adjustments.

FREQUENCY CHARACTERISTICS

Range
Accuracy
Resolution
Stability

MODULATION CHARACTERISTICS

External FM

The performance tests above are source dependent and can be found in the Performance Tests section of the Synthesizer Operating and Service Manual.

NOTE: When specifying the output frequency characteristics of the HP 8673C/D/83558A system, all frequency specifications are referenced from the sources used and must be multiplied by six because the HP 83558A multiplies the frequency by six. For special information about the multiplying components, refer to the "Theory of Operation" section found in the "Source Module Specifications and Service" section of this manual.

Table 2d-2. Performance Test Record

<h2 style="margin: 0;">HP 8673C/D System</h2> <p style="margin: 5px 0;">Serial Number _____ Date _____</p> <p style="margin: 5px 0;">Humidity* _____ Tested By _____</p> <p style="margin: 5px 0;">*(Optional) _____ Temperature* _____</p>				
Specifications Tested	Test Conditions	Specification	Test Results	
			Pass	Fail
<p>FREQUENCY</p> <p>Range¹ Accuracy (25°C ± 5°C)</p> <p>CW Mode</p> <p>Time Base</p> <p>All Sweep Modes (for sweep time > 100 msec)</p> <p>CW Resolution¹</p> <p>MODULATION External FM Maximum Deviations for Modulation Frequencies 100 Hz to 10 MHz (60,200 kHz/V ranges) 1 kHz to 10 MHz (2, 6, 20 MHz/V ranges)</p>	<p>_____</p> <p>_____</p> <p>_____</p> <p>_____</p> <p>_____</p> <p>_____</p> <p>_____</p>	<p>75.0 to 110.0 GHz¹</p> <p>Same as time base</p> <p>Internal 10 MHz time base Aging rate: less than 5×10^{-10}/day after 24-hour warmup.</p> <p>Temperature effect $< 1 \times 10^{-10}/^{\circ}\text{C}$</p> <p>Line Voltage effect $< 5 \times 10^{-10}/+5\%$ to -10%</p> <p>Same as time base</p> <p>18 kHz¹</p> <p>The smaller of 60 MHz or $f_{\text{mod}} \times 120$</p>	<p>_____</p> <p>_____</p> <p>_____</p> <p>_____</p> <p>_____</p> <p>_____</p> <p>_____</p>	<p>_____</p> <p>_____</p> <p>_____</p> <p>_____</p> <p>_____</p> <p>_____</p> <p>_____</p>

1. These specifications are six times those of the HP 8673C/D specifications because the HP 83558A multiplies the frequency by six.

TROUBLESHOOTING

Specification Failures

Failures are divided into two categories:

Category one describes systems that are meeting specifications in some areas, while failing others. If this is the case, do the following:

- Inspect the connectors and ensure that all connections are making good electrical contact.

- Inspect all cabling for breaks.

- Test again.

If the system fails at DIFFERENT points, there is probably a loose connection or a mechanical failure somewhere in the test setup. If the system fails at the SAME points, the instruments or cables may be defective. Refer to the appropriate operating and service manual for each individual instrument and perform the operator's checks to isolate any possible defective instrument.

Category two describes total specification failures. If the system fails any of the previous tests completely, do the following:

- Check the TEST SETUP for correct configuration of the instruments and connections.

- Inspect the connectors.

- Inspect the cables.

- Repeat the failed test.

If the system still fails to meet specifications, the millimeter-wave source module may be defective. However, it is possible that one of the other instruments is defective. Refer to the appropriate operating and service manual for each individual instrument and perform the operator's checks or abbreviated performance tests to ensure that the other instruments are working properly.

Test failures are possible due to measurement uncertainties. Also, for best accuracy in measurement, use only properly calibrated instruments.

**HP 83623A or HP 83624A
Source System Guide**

TABLE of CONTENTS
HP 83623A/24A SOURCE SYSTEM GUIDE

Introduction
System Specifications
Operation
Operator's Check
System Performance Tests
Introduction
Frequency Characteristics
Troubleshooting

Section 2e. HP 83623A/24A Source System Guide

INTRODUCTION

This source system guide is intended to provide you with mm-wave system operating information for the HP 83623A/24A synthesizers. It contains an operator's check, connection diagrams, system specifications, system performance tests, and system level troubleshooting. For detailed instructions regarding the operation or troubleshooting of the individual instruments, refer to the instrument's operating and service manual.

SYSTEM DESCRIPTION

The HP 83623A (10 MHz to 20 GHz) and 83624A (2 GHz to 20 GHz) synthesized sweepers (unless otherwise stated, will hereafter be referred to as the HP 83623A/24A) operates over the frequency range required by the HP 83558A millimeter-wave source module.

The HP 83623A/24A delivers the required 12.5 to 18.33 GHz input frequency and +17 dBm of output power for directly driving the HP 83558A source module.

WARNING

This equipment is capable of radiating millimeter-wave energy from the end of unterminated waveguide. Do not look directly into the open end of any waveguide when it is connected to a source of millimeter-wave energy.

Take precautions consistent with ANSI C95.1 - 1982, a study performed by the American National Standards Institute that sets limits for human exposure to microwave and millimeter-wave energy. Copies of this publication are available from:

**American National Standards Institute
1430 Broadway
New York, N. Y. 10018**

SYSTEM SPECIFICATIONS

Table 2e-1 provides specifications for the HP 83623A/24A synthesized sweeper/83558A system configuration. These are the performance standards against which the system is tested.

Table 2e-1. HP 83623A/24A/83558A System Specifications

Frequency Characteristics	Modulation Characteristics
Range75.0 to 110.0 GHz	External FM
Accuracy ¹ (25°C ± 5°C)	Bandwidth50 kHz to 10 MHz
CW ModeSame as time base	Deviationthe lesser of 12 MHz or 30 x Fmod
Time Base ²Internal 10 MHz time base	Sensitivity100 kHz/V, 1 MHz/V or 10 MHz/V
Aging rate: less than 5 x 10 ⁻¹⁰ /day and 1 x 10 ⁻⁷ /year after 30-day warmup.	External AM
Temperature Effect: < 1 x 10 ⁻¹⁰ /°C	Bandwidth, typicallyDC to 100 kHz
Line Voltage Effect: < 5 x 10 ⁻¹⁰ /± 10%.	Sensitivity, typically100%/V
All Sweep Modes	External Pulse Modulation
(for sweep time > 100 msec and < 5s) ³	Rise/Fall Time, typically50 ns
ΔF ≤ (n) 40 MHz+0.1% of ΔF ± time base accuracy	Minimum RF Pulse Width
(n) 60 MHz < ΔF ≤ 1800 MHz± 1% of ΔF	System Leveled1 us
1800 ≤ ΔF < 18 GHz: 18 MHz	System Unleveled100 ns
ΔF > 18 GHz: 0.1% of ΔF	On/off ratio, typically> 80 dB
n = harmonic band (1–4) of the HP 83623A/24A	Pulse Repetition Frequency
CW Resolution1 Hz	System Leveled10 Hz to 500 kHz
	System UnleveledDC to 5 MHz
	HP 8756A and 8757A
	AC Detection Mode CompatibilityYes

- Specifications referenced are source driver specific (HP 83623A/24A) and do not indicate the multiplying by six effect of the source module.
- Overall accuracy of internal timebase is a function of timebase calibration ± aging rate ± temperature effects ± line effects.
- After one hour warmup at selected CW frequency.

OPERATION

INTRODUCTION

This section is intended for operators familiar with the HP 83623A/24A instruments. If you are unfamiliar with this system, refer to the Operator's check at the end of this section for more specific instructions.

In the operation instructions, any instrument setting or function key is defined by [] symbols around it.

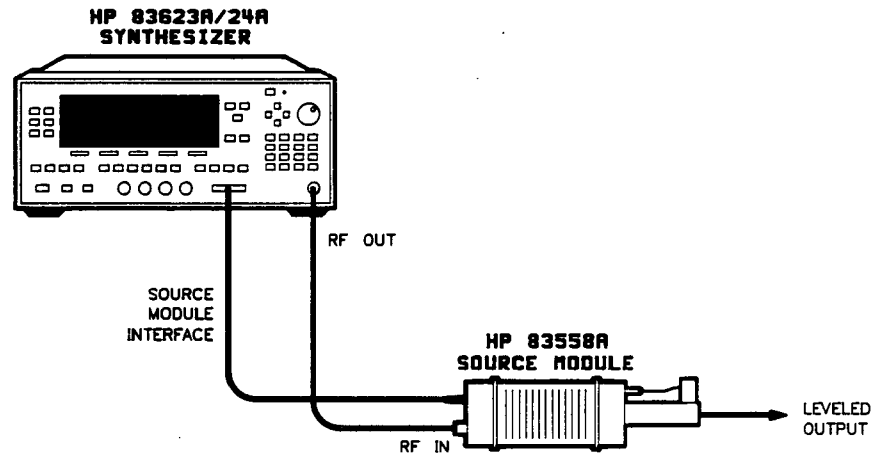

Figure 2e-1. HP 83623A/24A/83558A Source System Configuration

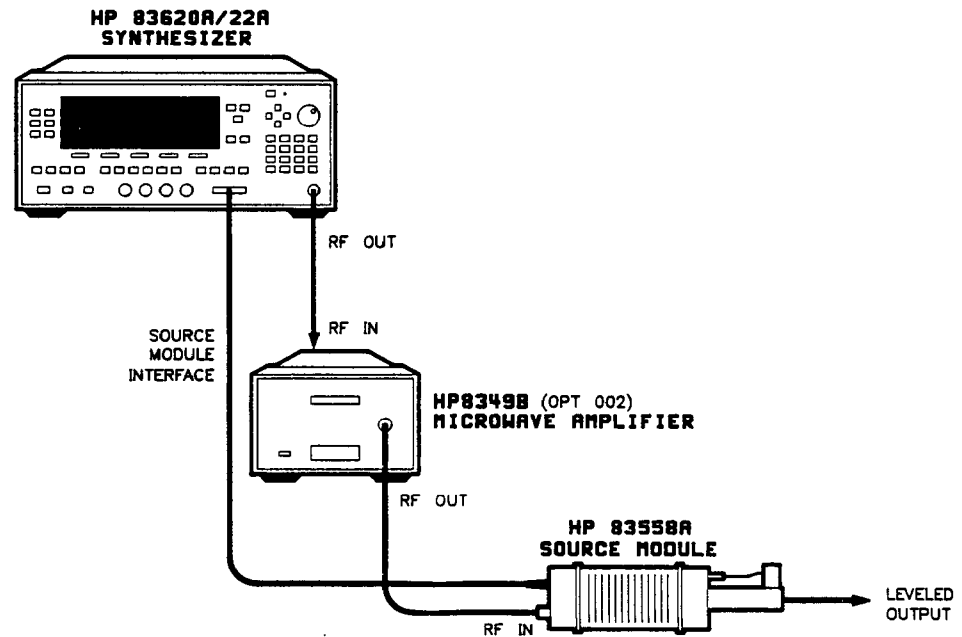

Figure 2e-2. HP 83620A/22A/40A/42A/83558A Source System Configuration

CAUTION

Turn off the ac power on the HP 8349B prior to connecting or disconnecting the source module interface cable.

Connect the system as shown in Figure 2e-1 or Figure 2e-2.

Throughout this Source System Guide, the configuration shown in Figure 2e-2, using the HP 83620A/22A/40A/42A with the HP 8349B, can be substituted for the HP 83623A/24A configuration shown in Figure 2e-1.

FREQUENCY CONTROL

After the connections have been made, turn on the system, and press **[PRESET]** on the HP 83623A/24A. Allow instruments to warm-up 30 minutes. The HP 83623A/24A will automatically read the frequency range of the source module and set the HP 83623A/24A to the appropriate start and stop frequencies.

POWER LEVEL CONTROL

CAUTION

Before performing any power level calibrations, ensure that the HP 83623A/24A synthesizer is not at maximum power.

Power is controlled by pressing **[POWER LEVEL]**. The step keys, rotary knob or keypad controls the output power from the synthesizer. The actual output power from the mm-wave source module is read on the HP 83623A/24A PWR dBm display in the system leveled mode.

POWER LEVELING

System Leveling

System leveling provides calibrated, flat power from the output of the mm-wave source module. The HP 83623A/24A/83558A configuration shown in Figure 2e-1 provides leveled source module output power with corrected power level flatness. With the **[Leveling Point Module]** key on, a portion of the source module power output is coupled out of a directional coupler and detector internal to the source module. This signal is applied to the HP 83623A/24A automatic leveling control circuitry (ALC). The source module output power is displayed on the HP 83623A/24A display.

External Power Meter Leveling

Output power may also be leveled with a power meter and a directional coupler as shown in Figure 2e-3. Power meter leveling at the source module output is possible using the power meters referenced in Table 1-1 (System General Information).

Set the ALC mode to [Leveling Point PwrMtr] on the HP 83623A/24A. The sweep time is limited to 100 seconds when this leveling method is used. A portion of the mm-wave output signal from the source module is coupled/detected and routed to the power meter. The DC voltage from the power meter recorder output is then applied to the HP 83623A/24A external ALC circuit.

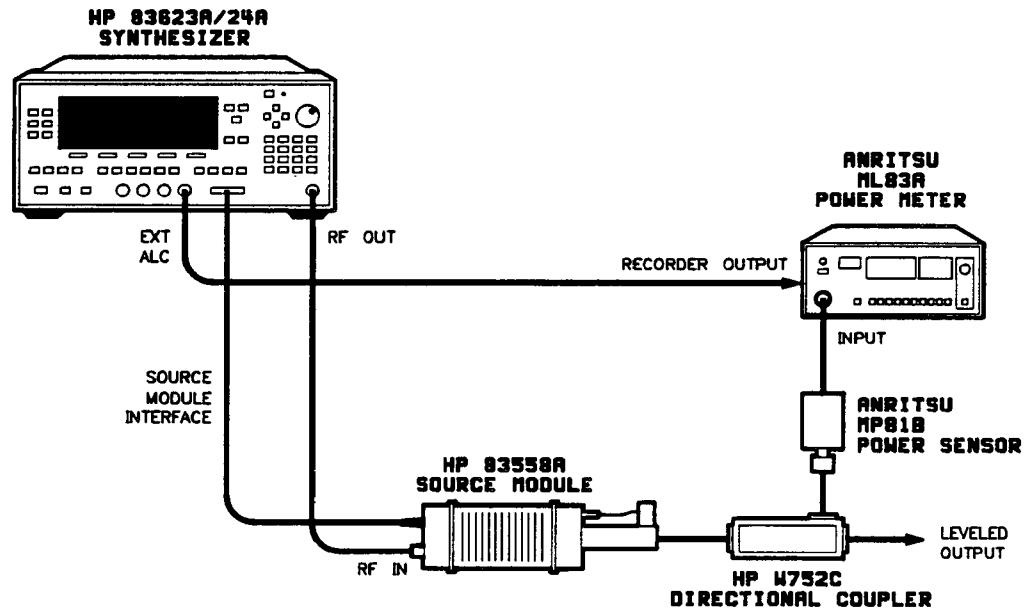

Figure 2e-3. External Power Meter Leveling at the HP 83558A Source Module Output

MODULATION

For complete specifications on all modulation modes described below, refer to Table 2e-1 (HP 83623A/24A/83558A System Specifications).

Frequency Modulation (FM Connector on HP 83623A/24A)

With the [FM On/Off DC] key activated, from the [MOD] menu, the source module may be frequency modulated from an external input signal. The FM deviation is multiplied by six by the HP 83558A source module but the displayed FM sensitivity remains correct.

FM sensitivities of 100 kHz/V, 1 MHz/V or 10 MHz/V are available over a bandwidth of 50 kHz to 10 MHz.

Amplitude Modulation (AM Connector on HP 83623A/24A)

When the [AM On/Off 100%/V] key is activated from the [MOD] menu, the AM input is used for linear, DC-coupled amplitude modulation. The small signal -3 dB bandwidth extends from DC to 100 kHz.

The sensitivity is 100% per volt. This means that $+1.0$ volt doubles the output voltage ($+6$ dB), while -1.0 volt shuts the output completely off.

For maximum modulation index, the HP 83558A source module should be set to a power level 3 dB below maximum power. (Note that 3 dB power is 6 dB volts.)

Pulse Modulation (PULSE Connector on HP 83623A/24A)

With the [**Pulse On/Off Extrnl**] key activated from the [**MOD**] menu, and the HP 83623A/24A system internally leveled, the application of a pulsed or square wave signal to the PULSE connector provides a pulsed or square wave modulated signal at the output of the HP 83558A. This input provides an ON/OFF power ratio of greater than 80 dB. The PULSE IN input is normally at a TTL HIGH (approximately +3 volts DC). When a TTL LOW signal (approximately 0 volts DC) is applied, the mm-wave output signal is turned off.

OPERATOR'S CHECK

DESCRIPTION

The following procedure will enable you to verify the proper operation of your HP 83623A/24A/83558A system by determining the system's output power and flatness performance over the W-band frequency range of 75.0 to 110.0 GHz at maximum leveled output power.

EQUIPMENT

Ensure that all the instruments below meet their own performance standards and have been recently calibrated to proper specifications before configuring them into the setup.

RF Signal Source	HP 83623A/24A Synthesized Sweeper
Power Meter	Anritsu ML83A
Power Sensor	Anritsu MP81B

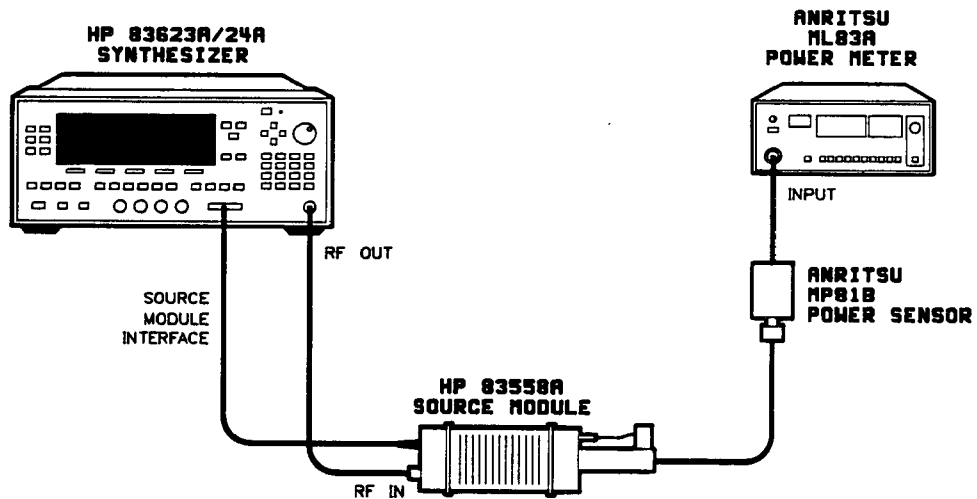

Figure 2e-4. System Configuration

PROCEDURE

1. Connect the equipment as shown in Figure 2e-4. Do not connect the power sensor to the HP 83558A output.



Turn off the AC power on the HP 83623A/24A prior to connecting or disconnecting from the source module interface connector.

2. Turn on all system components.
3. On the HP 83623A/24A:

Press [PRESET]

Press [CW] [7] [5] [GHz]

Connect the power sensor to the HP 83558A output.

Press [POWER LEVEL] and adjust rotary knob for a 0 dBm reading on the power meter display. Ensure that the power meter display is within 2.00 dB of the synthesizer display.

NOTE: Ensure that all modulation is in the **off** state or it will affect the accuracy of this test.

4. Press [CW]

While observing the power meter display, find the minimum power point between 75.0 to 110.0 GHz by slowly adjusting the rotary knob. Note at what frequency the minimum power point is. See Figure 2e-5.

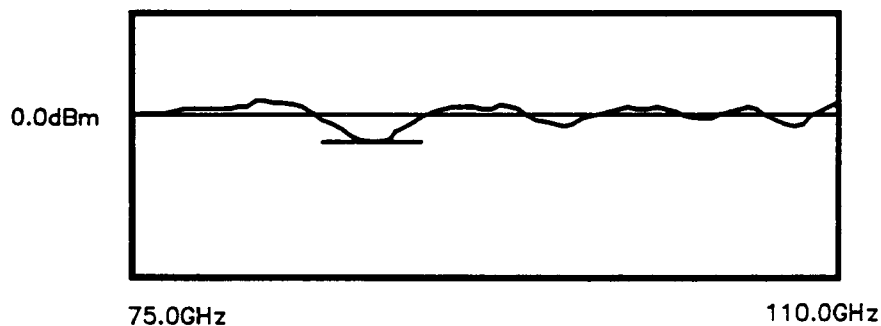

Figure 2e-5. Minimum Power Point (75.0 to 110.0 GHz)

Enter the frequency at the minimum power point by pressing [CW] XX.XX [GHz]

5. Press [POWER LEVEL] and adjust the rotary knob until you obtain a 0 dBm reading on the power meter display.
6. Press [CW]

Tune the rotary knob from 75.0 to 110.0 GHz and ensure that the power level displayed on the power meter never exceeds 3.0 dBm. This ensures that from 75.0 to 110.0 GHz, the system's power flatness is within ± 1.5 dB of maximum leveled power, 0 dBm. See Figure 2e-6.

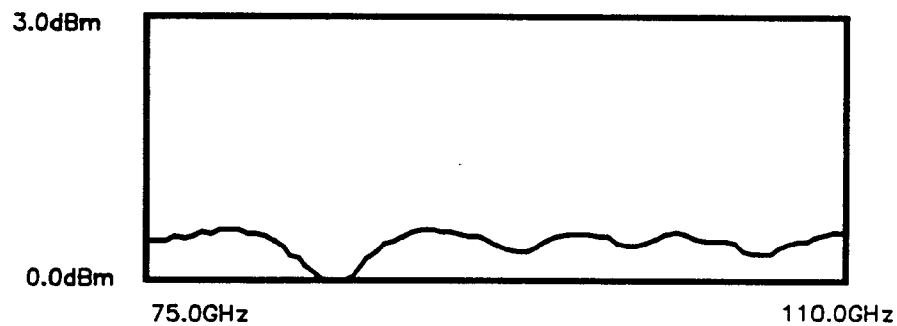

Figure 2e-6. Power Flatness Response (75.0 to 110.0 GHz)

This completes the Operator's Check. If your system fails this functional check, refer to the paragraph titled TROUBLESHOOTING.

SYSTEM PERFORMANCE TESTS

INTRODUCTION

The procedures in this section test the performance of the HP 83623A/24A/83558A source system using the specifications of Table 2e-1 as the performance standards. All tests can be performed without access to the interior of the instrument. The performance test procedures must be performed in the sequence given since some procedures rely on satisfactory test results in the foregoing steps. In order to fully verify the performance specifications of the HP 83558A, the performance tests in the Source Module Specifications and Service Section must also be performed. None of the tests require access to the interior of the instrument.

Under the paragraph, TROUBLESHOOTING, you will find information on what to do if your system fails to meet specifications.

EQUIPMENT REQUIRED

Equipment required for the performance tests are listed in the Recommended Test Equipment tables under the tabs Source System Guides, and Source Module Specifications and Service. Any equipment that satisfies the critical specifications given in the table may be substituted for the recommended models. Ensure also that the test equipment used is currently calibrated to proper specifications.

NOTE: Use only the connectors and cables that are specified in the following test setups to ensure accurate test results.

OPERATION VERIFICATION

The Operation Verification consists of performing the source module specific performance tests (Source Module Specifications and Service Section) which include, Maximum Leveled Power (verifies frequency range), Power Flatness, and Power Level Accuracy. These tests provide reasonable assurance that the source module is functioning properly and should meet the needs of an incoming inspection (80% verification).

TEST RECORD

Results of the performance tests may be recorded in the Test Record at the end of the procedures. The Test Record lists all of the tested specifications and their acceptable limits. Test results recorded at incoming inspection can be used for comparison in periodic maintenance and troubleshooting or after repairs.

FREQUENCY CHARACTERISTICS

Range
Accuracy
Resolution
Stability

The performance tests listed above are source dependent and are found under the following performance tests in the HP 83623A/24A synthesized sweeper Calibration Manual: Internal Time Base Aging Rate, Frequency Range and Swept Frequency Accuracy. The CW Accuracy of the HP 83623A/24A can be verified by the following: if the instrument passes the full self-test, and the instrument is phase-locked, the HP 83623A/24A is as accurate as the timebase. Only by performing these specific tests can the frequency characteristics of the HP 83623A/24A/83558A system be verified.

NOTE: When specifying the output frequency characteristics of the HP 83623A/24A/83558A system, all frequency specifications are referenced from the sources used and must be multiplied by six because the HP 83558A multiplies the frequency by six. For special information about the multiplier components, refer to the "Theory of Operation" section found in the "Source Module Specifications and Service" section of this manual.

Table 2e-2. Performance Test Record

HP 83623A/24A Series System				
Serial Number _____		Date _____		
Humidity* _____		Tested By _____		
(Optional)		Temperature _____		
Specifications Tested	Test Conditions	Specification	Test Results	
FREQUENCY				
Range ¹	_____	75.0 to 110.0 GHz ¹	_____	_____
Accuracy (25°C ± 5°C)	_____		_____	_____
CW Mode	_____	Same as time base	_____	_____
Time Base	_____	Internal 10 MHz time base Aging rate: less than 5×10^{-10} /day and 1×10^{-7} /year after 30-day warmup.	_____	_____
	_____	Temperature effect $< 1 \times 10^{-10}/^{\circ}\text{C}$	_____	_____
	_____	Line Voltage effect $< 5 \times 10^{-10} \pm 10\%$	_____	_____
All Sweep Modes (for sweep time > 100 msec and $\leq 5\text{S}$)	_____	$\Delta F \leq (n) 60 \text{ MHz}$: $\pm 0.1\%$ of $\Delta F \pm$ time base accuracy (n) $60 \text{ MHz} < \Delta F \leq 1800 \text{ MHz}$: $\pm 1\%$ of ΔF $1800 \text{ MHz} < \Delta F \leq 18 \text{ GHz}$: 18 MHz $\Delta F > 18 \text{ GHz}$: 0.1% of ΔF n = harmonic band (1-4) of the HP 83623A/24A	_____	_____
CW Resolution	_____	1 Hz	_____	_____

TROUBLESHOOTING

Specification Failures

Failures are divided into two categories:

Category one describes systems that are meeting specifications in some areas, while failing in others. If this is the case, do the following:

- Inspect the connectors and ensure that all connections are making good electrical contact.

- Inspect all cabling for breaks.

- Test again.

If your system is still failing at the SAME points, your instrument(s) or cable(s) could be defective and should be returned for repair. If, however, your system fails at DIFFERENT points, there is probably a loose connection or a mechanical failure somewhere in the setup.

Remember, it is possible the system may fail the performance test(s) because of measurement uncertainties. If you suspect this to be the case, contact your nearest HP office for more information.

Category two failures are total specification failures. If your system fails any of these tests completely, do the following:

- Check the TEST SETUP for correct configuration of the instruments and connections.

- Inspect the connectors.

- Inspect the cables.

- Repeat the failed test(s).

If your system is still failing, the system is probably defective and needs repair.

Also, for the best accuracy in measurement, use only calibrated instruments.

**Source Module
Specifications and Service**



TABLE of CONTENTS

SPECIFICATIONS AND SERVICE

- Introduction**
- Specifications**
- Description**
- Equipment Required But Not Supplied**
- Recommended Test Equipment**
- Initial Inspection**
- Mating Connectors**
- Preparation For Use**
- Performance Tests**
 - Introduction**
 - Equipment Required**
 - Operation Verification**
 - Test Record**
 - Calibration Cycle**
 - Maximum Leveled Power Test**
 - Power Level Flatness Test**
 - Power Level Accuracy Test**
 - Output SWR Test**
 - Multiplier Harmonic Test**
- Service**
 - Introduction**
 - Safety Considerations**
 - Service Procedure**
 - Adjustments**
 - Theory of Operation**
 - Troubleshooting**
 - Block Diagram**
 - Replaceable Parts**

Section 3. Source Module Specifications and Service

INTRODUCTION

This section contains information that is specific to the HP 83558A source module: instrument specifications, theory of operation, procedures for performance tests, and a replaceable parts list. For detailed instructions regarding the operation or troubleshooting of an individual instrument other than the source module, refer to that particular instrument's operating and service manual.

SPECIFICATIONS

Source module specifications are divided into two categories:

- Source driver dependent specifications (system specifications).
- Source module specifications independent of signal source.

Because the HP 83558A source module uses frequency multiplication to generate millimeter-wave frequencies, source module frequency specifications are directly proportional to those of the external signal source driving the source module. The specifications that are an extension of the external signal source are detailed in the Source System Guide (Table 2-1) for that particular source system configuration.

Specifications for the source module that are independent of the source driver are listed in Table 3-1 of this section. These performance standards together with the performance standards listed in the Source System Guide that describes the system you are using, are the limits against which the instrument can be tested.

If source system conformance to specifications is required, BOTH (source system and source module) sets of performance tests must be performed to completely verify instrument conformance to the specifications.

Table 3-1. HP 83558A Specifications and Supplemental Characteristics

SPECIFICATIONS				
Specifications describe the instrument's warranted performance over the temperature range 20° to 30°C. Supplemental characteristics are intended to provide information useful in applying the instrument by giving typical but non-warranted performance parameters.				
HP 83558A 75 to 110 GHz	HP 8350B/83550A or HP 8350B/83592C/95C HP 8349B	HP 83623A or HP 83624A	HP 8341B Opt. 003' HP 8349B	HP 8673C/D' HP 8349B
Leveled Power Range:	-5 to +0 dBm	-5 to +0 dBm	-5 to +0 dBm	-5 to +0 dBm
Unleveled (Opt 001):	-5 to +1 dBm	-5 to +1 dBm	-5 to +1 dBm	-5 to +1 dBm
Power Level Accuracy:	±2.5 dB	±2.0 dB	±2.5 dB	±2.5 dB
Power Flatness (Maximum Leveled Power):	±2.0 dB	±1.5 dB	±2.0 dB	±2.0 dB
Source Output SWR				
Leveled:	2.0	2.0	2.0	2.0
Unleveled (typical):	3.0	3.0	3.0	3.0
Spurious Signals²	-20 dBc	-20 dBc	-20 dBc	-20 dBc

1. Specifications apply for low harmonic sources only. The standard HP 8340B/8341B and the HP 8673B/G/H also provide the same source capabilities except the spurious output of the modules is at 0 dBc.

2. Expressed in dB relative to the carrier (dBc).

SUPPLEMENTAL CHARACTERISTICS				
Frequency Accuracy, Resolution, and Stability:	6 times the frequency accuracy, resolution, and stability of the input signal. Accuracy is the same as the time base for synthesized sources.			
External Pulse Modulation On/Off Ratio (typical):	> 80 dB (>60 dB for HP 83550A)	> 80 dB	> 80 dB	> 80 dB
Rise/Fall Time (typical):	10 ns (25 ns for HP 83550A)	50 ns	50 ns	40 ns
Minimum Leveled RF Pulse Width (typical)	1µs	1µs	1µs	1µs
Amplitude Modulation Rate (3 dB BW) (typical):	DC - 100 kHz	DC - 100 kHz	DC - 100 kHz	DC - 100 kHz
Sensitivity (typical):	1 dB/V		(100%/V, for synthesized sources)	

DESCRIPTION

The HP 83558A source module is a frequency multiplier that uses a 12.5 to 18.33 GHz input frequency range. The HP 83558A multiplies the input frequencies by six to generate an output frequency range of 75.0 to 110.0 GHz. The RF power and control signals for the mm-wave source module are obtained from a source driver. For specified performance, the input RF energy must be between +17 dBm and +27 dBm through the RF cable provided with the source module. All the power supplies and control signals are applied to the source module through the source module interface cable.

The source module cables and connectors are detailed in Figure 3-1.

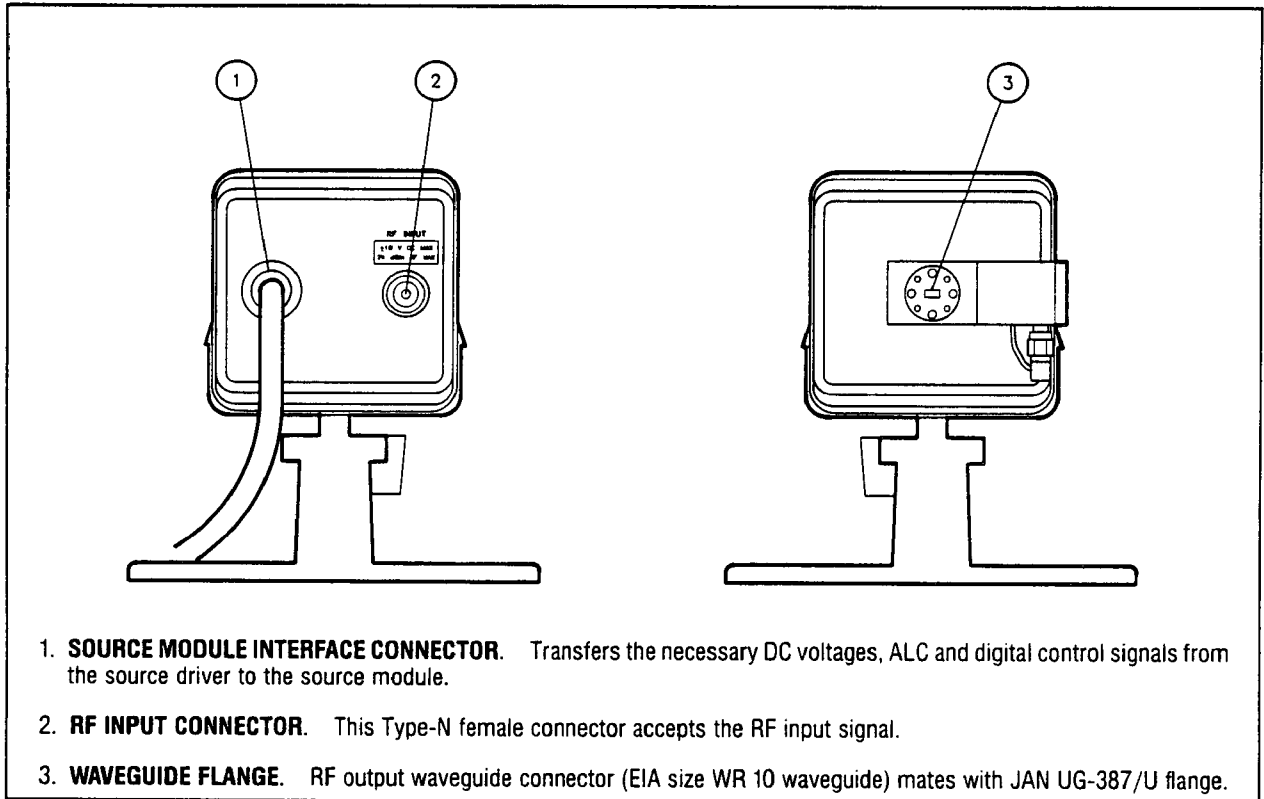

Figure 3-1. HP 83558A Features

EQUIPMENT REQUIRED BUT NOT SUPPLIED

For information on accessories and instruments used in a source module system, refer to Figure 1-3 and to Tables 1-1 and 1-2 in System General Information.

RECOMMENDED TEST EQUIPMENT

The equipment required for testing and/or troubleshooting the instrument is listed in Table 3-2. Other equipment may be substituted if it meets or exceeds the critical specifications indicated in the table.

MATING CONNECTORS

The HP 83558A output connector is EIA size WR 10 waveguide. This waveguide mates directly with a UG-387/U cover flange.

PREPARATION FOR USE

For information on site preparation, operating environment, and safety considerations, refer to the System General Information section of this manual.

Table 3-2. Recommended List of Test Equipment

Instrument	Critical Specifications	Recommended Model
source		Refer to Figure 1-3 in the System General Information section.
microwave amplifier	15 dB gain to 20 GHz non-harmonic spurious: >50 dBc	HP 8349B
spectrum analyzer	2 to 20 GHz coverage two channel display, waveform storage and normalization	HP 8566B
power meter	-10 to +20 dBm programming capability	Anritsu ML83A
power sensor	W-band 75.0 to 110.0 GHz	Anritsu MP81B
microwave amplifier	2 to 8 GHz coverage	HP 11975A
waveguide detector adapter	W-band 75.0 to 110.0 GHz	HP 85025C
waveguide detector	W-band 75.0 to 110.0 GHz	HP 85025C K71
waveguide short	W-band 75.0 to 110.0 GHz	HP W920B
waveguide load	W-band 75.0 to 110.0 GHz	HP W914B
waveguide coupler	W-band 75.0 to 110.0 GHz, 10 dB	HP W752C
waveguide coupler	W-band 75.0 to 110.0 GHz, 20 dB	HP W752D
harmonic mixer	W-band 75.0 to 110.0 GHz	HP 11970W
RF cables (3)		HP Part No. 5061-5458

SOURCE MODULE PERFORMANCE TESTS

INTRODUCTION

The procedures in this section test the source module's electrical performance to the specifications in Table 3-1. Because the specifications tested in this section are not dependent on the source driver, any system configuration described in Figure 1-3 of the System General Information Section can be used. All of the tests in this section can be performed without access to the interior of the instrument. A simpler operational test is included in all of the Source System Guides, under Operator's Check.

The words "press" and "select" will be used to mean "press key named...". "Press" references a front panel labeled key and "select" is used to reference softkeys.

NOTE: Ensure that all the test equipment used meets its own performance standards and has been recently calibrated to proper specifications before performance testing.

The performance test procedures must be performed in the sequence given, because some procedures rely on satisfactory test results in foregoing steps. If a test measurement is out of tolerance, refer to the troubleshooting paragraphs in this section.

NOTE: Allow the HP 83558A and system components to warm up for one hour prior to doing any performance tests.

EQUIPMENT REQUIRED

Equipment required for testing the source module is listed in Table 3-2, the Recommended Test Equipment in this section, and in Figure 1-3 in System General Information. Any equipment that satisfies the critical specifications given in the table may be substituted for the recommended models. All of the recommended RF sources must be equipped with the 0.5V/GHz frequency reference capability.

OPERATION VERIFICATION

Operation Verification consists of performing the first three performance tests in this section. These tests provide reasonable assurance that the source module is functioning properly and should meet the needs of an incoming inspection (80% verification).

TEST RECORD

Results of the performance tests can be recorded in the Test Record at the end of the procedures. The Test Record lists all of the tested specifications and their acceptable limits. Test results recorded at incoming inspection can be used for comparison in periodic maintenance, troubleshooting, or after repairs.

CALIBRATION CYCLE

The performance tests in this section should be performed every twelve months. The instruments in the source system configuration should be performance tested as indicated in the appropriate operating and service manual.

WARNING

This equipment is capable of radiating millimeter-wave energy from the end of unterminated waveguide. Do not look directly into the open end of any waveguide when it is connected to a source of millimeter-wave energy.

Take precautions consistent with ANSI C95.1 - 1982, a study performed by the American National Standards Institute that sets limits for human exposure to microwave and millimeter-wave energy. Copies of this publication are available from:

**American National Standards Institute
1430 Broadway
New York, N. Y. 10018**

MAXIMUM LEVELED POWER TEST

Specification

Maximum Leveled Power (25°C ± 5°C): +0 dBm

Description

Using the following procedure, you can verify the maximum leveled output power performance of your HP 83558A mm-wave source module. The output power of the source driver is set for maximum power out. A frequency range is manually swept while observing a power meter to locate the lowest power point. The source driver power control is adjusted at the frequency of the lowest power point until the unlevelled light turns off. The frequency range is manually swept again and the power is observed on the power meter to ensure the specified power is met.

Equipment

Source Driver	Any source in Figure 1-3 of System General Information
Power Meter	Anritsu ML 83A
Power Sensor	Anritsu MP81B

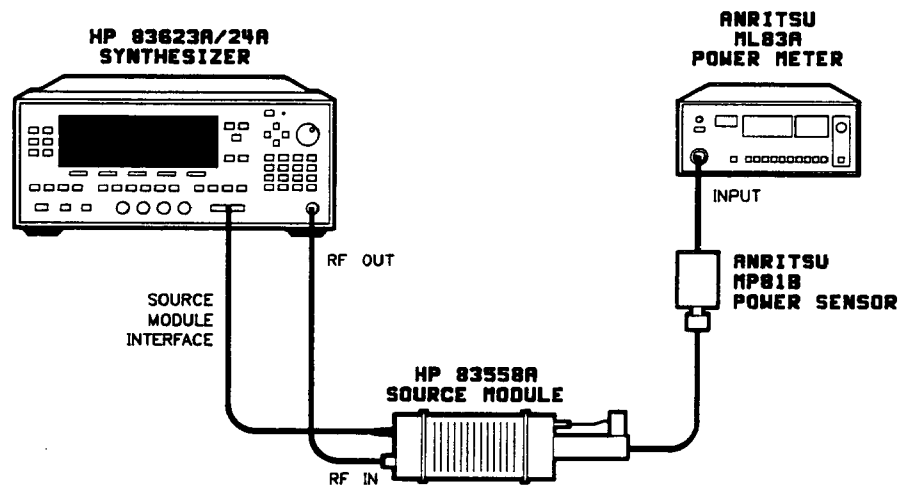

Figure 3-2. Typical Maximum Leveled Power Test Setup (without an amplifier)

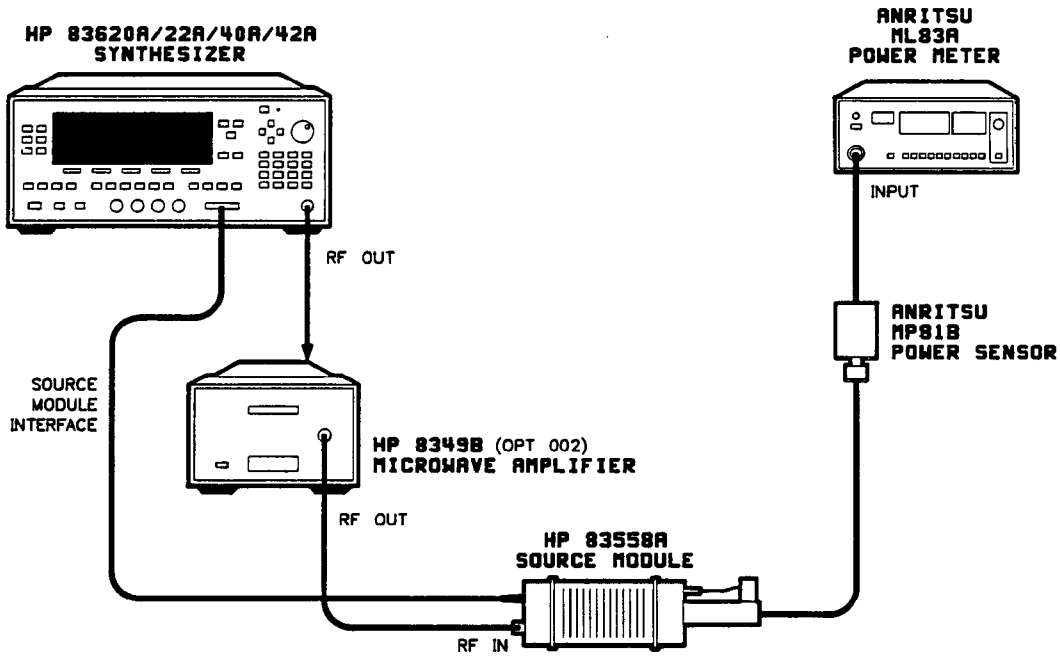

Figure 3-3. Typical Maximum Leveled Power Test Setup (with an amplifier)

Procedure

1. Connect the equipment in one of the mm-wave system configurations. (Refer to Figure 1-3 in System General Information.)

NOTE: Turn off the AC power when connecting to or disconnecting from any component of the mm-wave system configuration.

2. Turn on all system components.

Press [INSTR PRESET]

3. On the RF source, select the external leveling mode (leveling point [MODULE] for HP 8360 series sources) and set the power for maximum power out. The unlevelled light should be on.
4. Select a MANUAL SWEEP from 75.0 to 110.0 GHz.

NOTE: Ensure that all modulation on the source is off or it will affect accuracy of this test.

5. Manually sweep the frequency range, observing the power meter to locate the lowest power point.
6. At the lowest power point, adjust the power control until the RF source unlevelled light turns off.
7. Manually sweep the frequency range again, watching the unlevelled light to make sure that it stays off across the entire band. If the unlevelled light turns on, stop at the frequency where this occurs, and adjust the power level until the light goes off.
8. When the unlevelled light stays off across the entire frequency band, find the minimum power point and stop at this frequency. Adjust the power meter calibration factor, as referenced on the power sensor, for the low power point frequency. Measured power should be $> +0$ dBm.

POWER LEVEL FLATNESS TEST

Specification

Power Flatness (at maximum specified power; 25°C ± 5°C)

System Levelled ±1.50 dB (HP 83623A/24A)
±2.00 dB (all others)

Description

A power meter is used to check power level flatness at 0 dBm from 75.0 to 110.0 GHz.

Equipment

Source Driver	Any source in Figure 1-3 of System General Information
Power Meter	Anritsu ML83A
Power Sensor	Anritsu MP81B

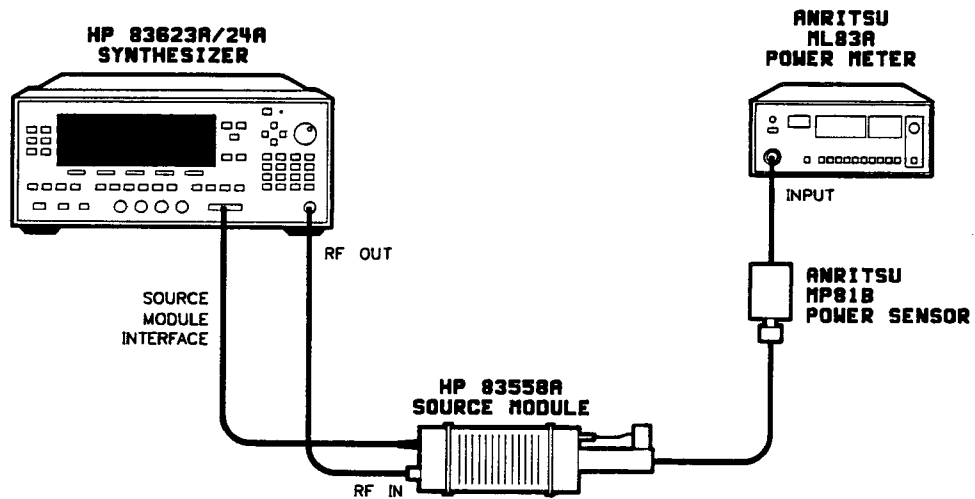

Figure 3-4. Typical Power Flatness Test Setup

Procedure

1. Connect the equipment in one of the mm-wave source module system configurations. (Refer to Figure 1-3 in System General Information.)

NOTE: Turn off the AC power when connecting to or disconnecting from any component of the mm-wave system configuration.

2. Turn on all system components.
3. Select MANUAL SWEEP from 75.0 GHz to 110.0 GHz on the RF source.
4. Select external leveling mode on the RF source driver and set the source module output power for 0 dBm.

NOTE: Ensure that the SQ MOD control on the source is off or it will affect the accuracy of this test.

5. Manually sweep the frequency range and locate the lowest power point using a power meter.
6. Set the calibration factor, as referenced on the power sensor, for the low power point frequency. Set this point to a measured +0 dBm with the power control on the source driver.
7. Manually sweep the frequency range again while viewing the measured output power. The power out should not exceed +4.0 dBm (+3.0 dBm for the HP 83623A and 83624A).

NOTE: This is a brief procedure of a test that appears earlier in this manual. For more detailed information on this test, refer to the Operator's Check in any of the Source System Guides.

POWER LEVEL ACCURACY TEST

Specification

Power Level Accuracy ($25^{\circ}\text{C} \pm 5^{\circ}\text{C}$):

System leveled ± 2.00 dB (HP 83623A/24A)
 ± 2.50 dB (all others)

Description

The frequency range is manually swept at three different power settings while observing a power meter for locating the minimum and maximum power points.

Equipment

Source Driver Any source in Figure 1-3 of
System General Information
Power Meter Anritsu ML83A
Power Sensor Anritsu MP81B

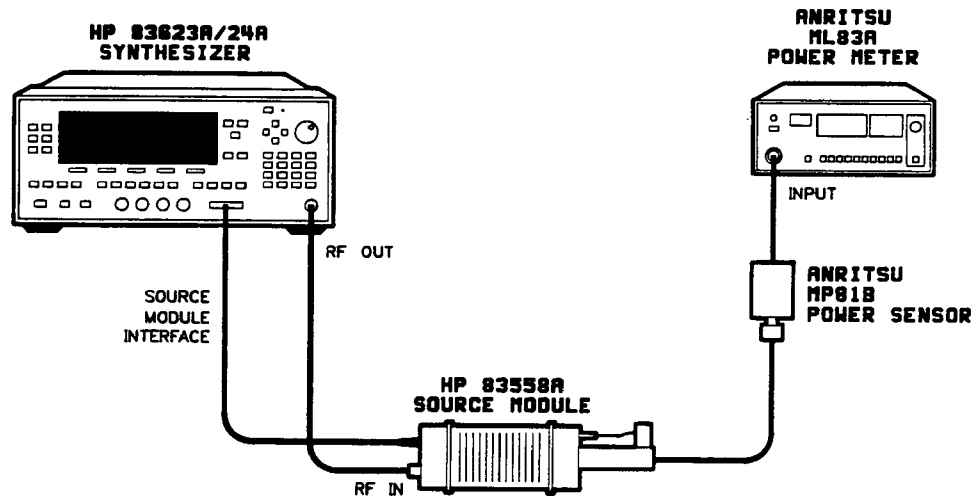

Figure 3-5. Typical Power Level Accuracy Test Setup

Procedure

NOTE: Ensure that the source module meets the power flatness performance test specifications before performing this test. If it does not, the results of this test may be invalid and may not meet specifications.

1. Connect the equipment in one of the mm-wave source module system configurations. (Refer to Figure 1-3 in System General Information.)

NOTE: Turn off the AC power when connecting to or disconnecting from any component of the mm-wave system configuration.

2. Turn on all system components.
3. Select a MANUAL SWEEP from 75.0 to 110.0 GHz
4. Set the RF source driver for external leveling mode (leveling point [MODULE] for HP 8360 series sources), and set the source module output power for +0 dBm.

NOTE: Ensure that the SQ MOD control on the source is off or it will affect the accuracy of this test.

5. Manually sweep the frequency range while using a power meter for measurement. Locate the lowest power point. Note frequency and adjust power meter calibration factor, as referenced on the power sensor, for the frequency at the low power point. The measured power should be > -2.0 dBm.
6. Sweep the frequency range again while observing the power meter display and find the maximum power point. Note frequency and adjust power meter calibration factor, as referenced on the power sensor, for the frequency at the maximum power point. The measured power should be $< +2.0$ dBm.
7. Repeat steps 4, 5, and 6, using the following power settings (HP 8362xA):

Displayed Power	Minimum Power	Maximum Power
-3 dBm	≥ -5.0 dBm	≤ -1.0 dBm
-5 dBm	≥ -7.0 dBm	≤ -3.0 dBm

NOTE: For all others add ± 0.5 dB to the minimum and maximum values shown above.

OUTPUT SWR TEST

Specification

Output SWR ≤ 2.0

Description

The Output SWR test measures the RF output signal using a directional coupler, an AC/DC detector, and a scalar network analyzer. A load is placed on the end of the waveguide to prevent any reflections from being seen at the coupled port. The signal at the end of the coupled port is then stored into the scalar network analyzer memory. A short is then placed on the waveguide, the scalar network analyzer is set to display measurement minus memory, and the maximum change in power is measured. The dB value of the maximum point on the scalar network analyzer is determined and this value is then converted to SWR using a conversion chart.

Equipment

Source Driver	Any Source in Figure 1-3 of System General Information
Scalar Network Analyzer	HP 8757A
Detector	HP 85025C K71
Detector Adapter	HP 85025C
Waveguide Coupler	HP W752C
Waveguide Load	HP W914B
Waveguide Short	HP W920B

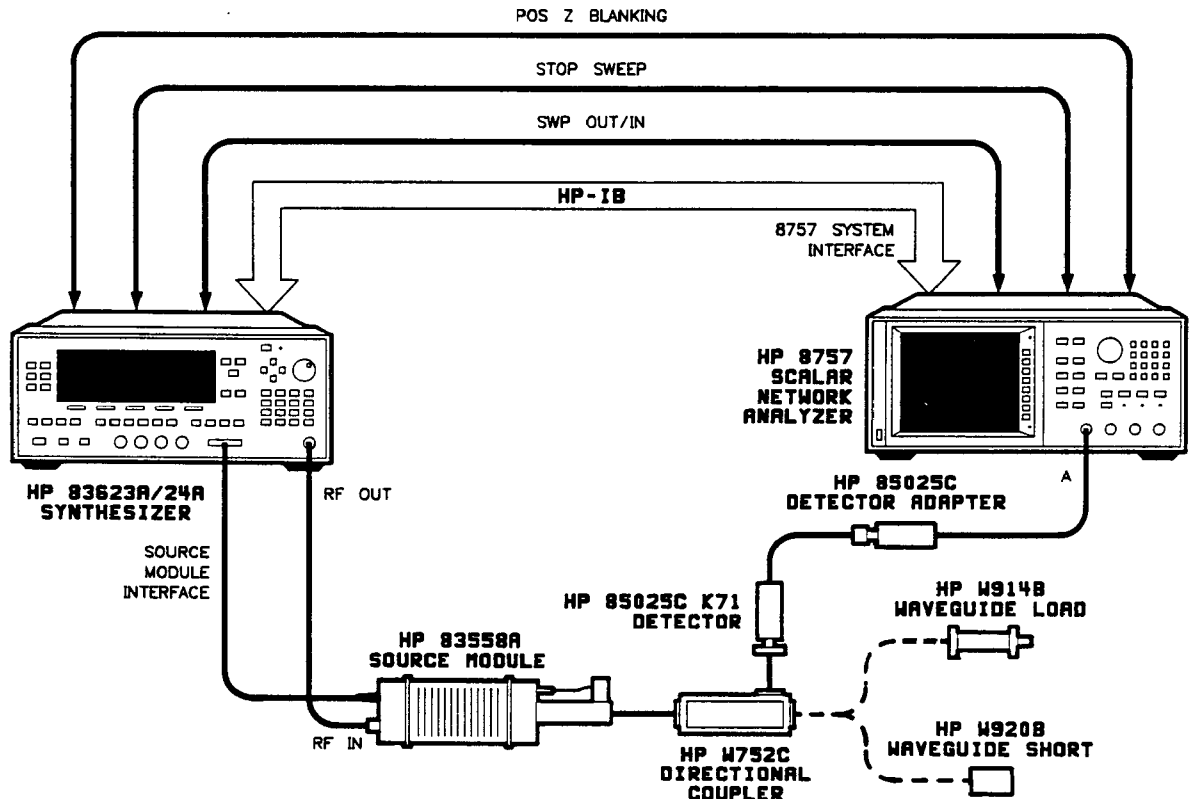

Figure 3-6. Output SWR Test Setup

Procedure

1. Connect the equipment as shown in Figure 3-6 with the load connected to the waveguide.
2. Set the source driver as follows:

Instr Preset

External Leveling Mode (leveling point [EXTERNAL] for HP 8360 series sources).

Power Level: +0 dBm

Sweep Speed: 200 ms

SQ Mod: Off (all pulse modulation OFF)

3. Set the scalar network analyzer as follows:

Channel A

DC Det Mode (under SYSTEM menu)

Reference Level: Approximately -5 dBm

dB/Div: 1dB

Reference Position: Center of CRT

4. Observe a display on the scalar network analyzer of leveled power.
5. Perform a normalized calibration as follows:
Under the MEAS menu select channel A.
Under the DISPLAY menu select MEAS, then MEAS→MEM, and finally MEAS-MEM.
6. Disconnect the waveguide load and replace it with the sliding short. Adjust the sliding short through its entire range and note the largest peak-to-peak variation on the scalar network analyzer display.
7. Calculate the SWR using Figure 3-7 as follows:
 - a. Find the largest peak-to-peak variation (noted in step 6) on the left vertical scale.
 - b. Find the intersection of the peak-to-peak variation and the 1.0 dB loss curve.
 - c. Move vertically down from the intersection to read the SWR on the bottom horizontal scale. The SWR should be ≤ 2.0 .

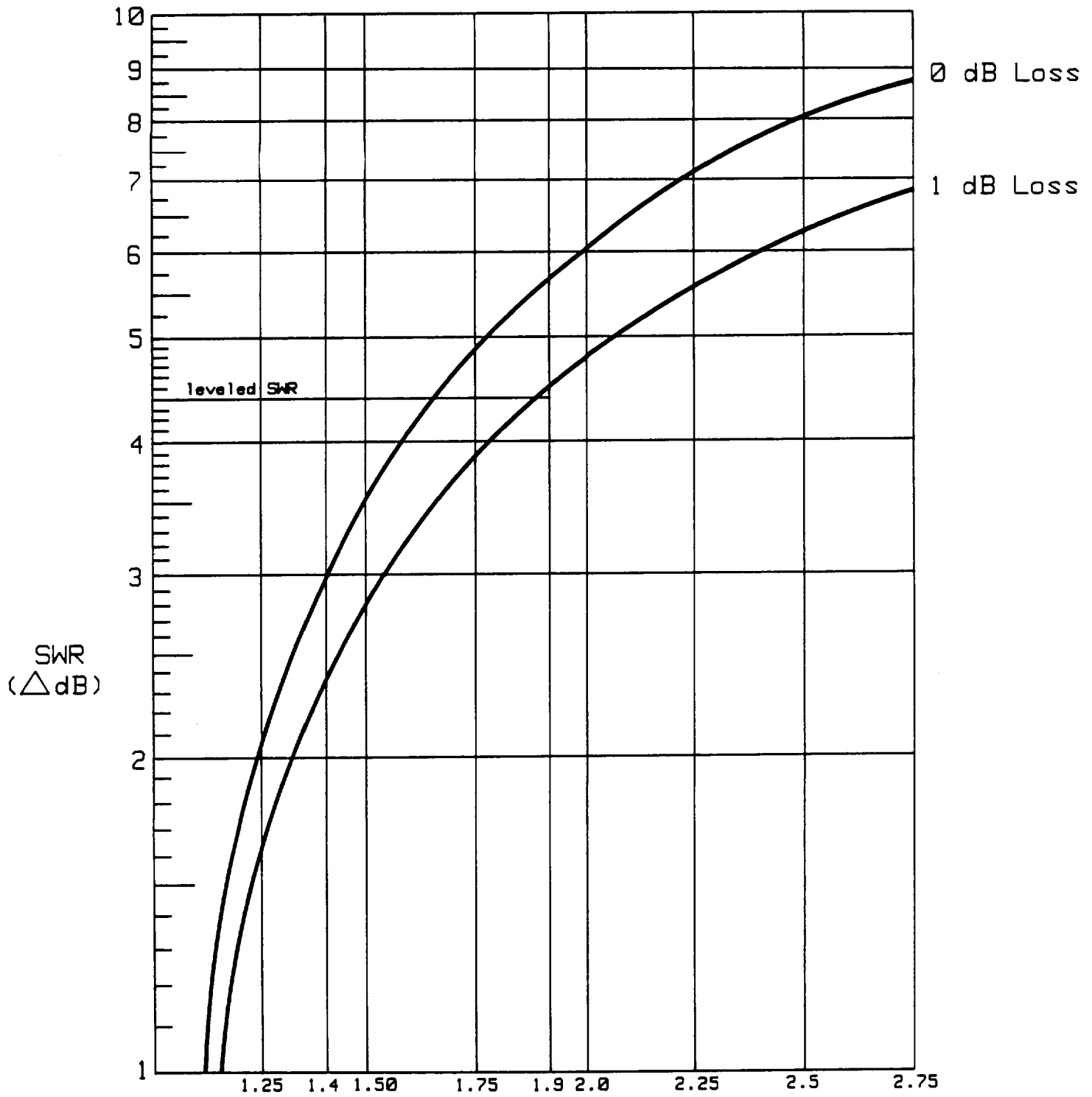

Figure 3-7. Conversion Chart

MULTIPLIER HARMONIC TEST

Specification

Harmonic Related > 20 dBc

Description

The following procedure addresses the 4/3 multiplier harmonic response. The location of the 4/3 harmonic can be calculated by using the equation in the procedure of this test. For any CW output signal between 75.0 and 82.5 GHz from the HP 83558A mm-wave source module, an accompanying 4/3 harmonic response may be present in the W-band frequency range of 100.0 to 110.0 GHz.

The RF output signal from the source module is tuned from 75.0 to 82.5 GHz and the 4/3 harmonics are displayed on a spectrum analyzer to verify that any harmonic spurious signals are at or below their specified levels. The test configuration in Figure 3-8 uses an external harmonic mixer to extend the frequency range of the spectrum analyzer. When this technique is used, the response is not pre-selected and multiple signals are displayed. Each response is examined not only for power level, but whether or not the signal is truly in band by using the spectrum analyzer's signal identification function.

Equipment

Source Driver	Any source in Figure 1-3 of System General Information
Spectrum Analyzer	HP 8566B
Waveguide Coupler	HP W752D
Harmonic Mixer	HP 11970W
RF Cables (3)	HP Part No. 5061-5458
Microwave Amplifier	HP 11975A
Power Meter	Anritsu ML83A
Power Sensor	Anritsu MP81B

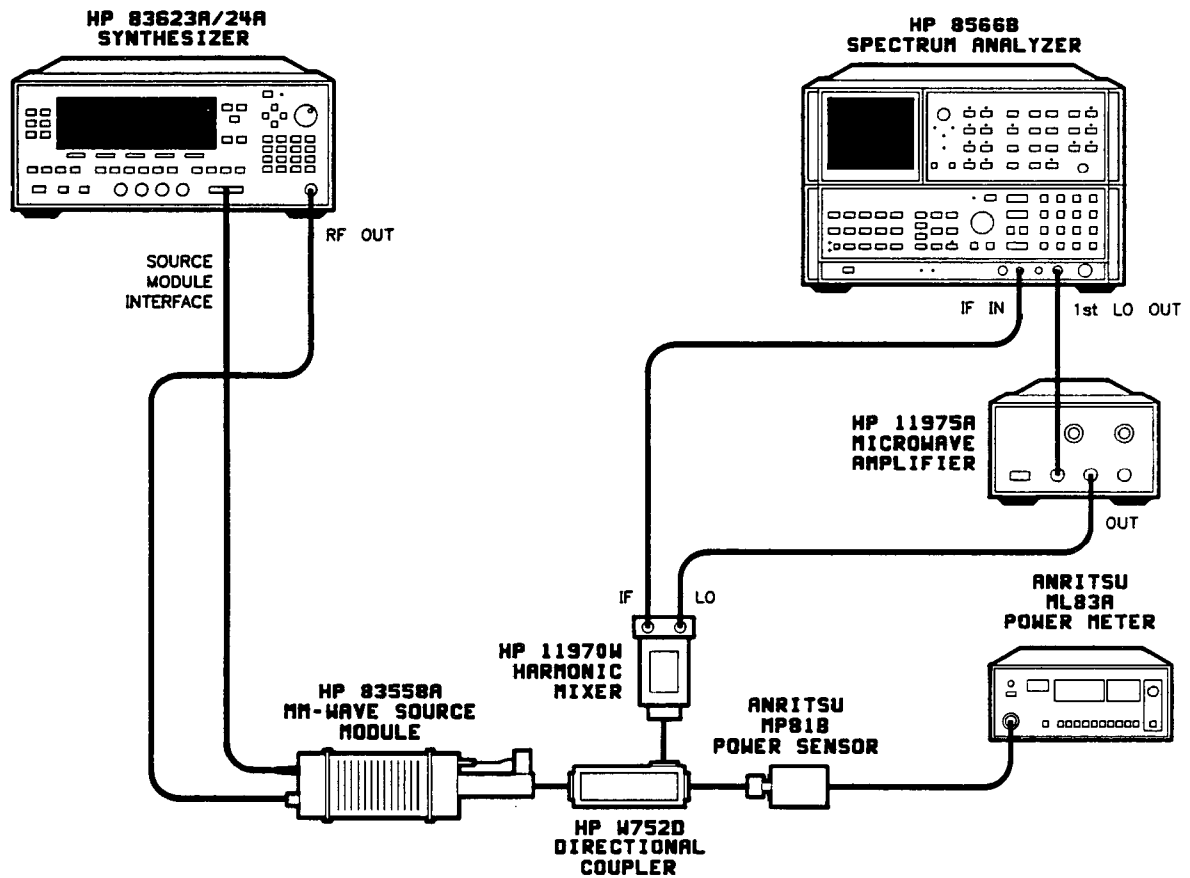

Figure 3-8. Multiplier 4/3 Harmonic Signals Typical Test Setup

Procedure

1. Connect the equipment as shown in Figure 3-8. Turn on all system components. On HP 8360 series sources, press [PRESET].

Multiplier Harmonic Signals

The 4/3 multiplier harmonic signals are determined from the calculation below.

Fundamental Frequencies	Harmonics
$F_3 = 75.0 \text{ to } 82.5 \text{ GHz}$	$4/3 \times F_3$

2. On the source driver set up a CW frequency of 75.0 GHz. Select the external leveling mode (leveling point [MODULE] for HP 8360 series sources), and set the power for 0 dBm.
3. Measure the source module output power with the power meter to ensure the power is 0 dBm.

4. On the HP 8566B:

Press [INSTR PRESET]

Press [SHIFT] [▲] [▲] [▲] [▲] [▲] [▲] [▲] until the **FULL BAND 12 (W)** annotation appears. This places the analyzer into an external mixing mode allowing V-band frequency range capability. Note the start/stop frequency at the bottom of the screen and ensure that the start frequency is 75.0 GHz and the stop frequency is 110.0 GHz.

Press [REF LEVEL] [0] [.] [0] [+dBm]

Press DISPLAY LINE [ENTER] [2] [0] [-dBm], setting the 20 dBc reference.

Amplitude Calibration of the HP 8566B

The HP 8566B spectrum analyzer can make amplitude calibrated measurements of millimeter-wave frequencies when configured with the HP 11970 mixers. A calibration graph that shows conversion loss and reference level offset is provided with each mixer so that the analyzer can be corrected to that mixer. The following explanation illustrates how this offset is entered into the spectrum analyzer.

In the external mixing mode, the HP 8566B gain is automatically set to 30 dB to compensate for the conversion loss of an external mixer. Using the information from the graph supplied with the mixer, you can offset the reference level to obtain precise amplitude calibration for point by point frequency measurements.

If more general measurements are required, averaging the conversion loss graph on the HP 11970 can be accomplished by averaging the graph's maximum and minimum power points resulting in an overall conversion loss for the entire band. By using this method, an increase of measurement uncertainty is introduced into the test. Reference level offset is determined by the following equation:

$$\text{Conversion Loss} - 30 \text{ dB} = \text{Reference Level Offset}$$

Because the test configuration in Figure 3-7 specifies that the external mixer be connected to the coupled arm of a 20 dB directional coupler, the coupled power must also be taken into account when calculating reference level offset. The new equation is as follows:

$$\text{Conversion Loss} + \text{Coupled Power (20 dB)} - 30 \text{ dB} = \text{Reference Level Offset}$$

For example, if the calibration table on the external mixer indicates a conversion loss of 42 dB for a frequency of 75.0 GHz and a 20 dB directional coupler is used, then the reference level offset is calculated below:

$$\text{Conversion Loss} + \text{Coupled Power (20 dB)} - 30 = \text{Reference Level Offset}$$

$$42 \text{ dB} + 20 \text{ dB} - 30 = +32 \text{ dB}$$

Enter this reference level offset by pressing:

[SHIFT] [REF LEVEL] [3] [2] [+dBm]

Note that the left hand side of the display will read:

CNVLOSS
62.0
dB

5. On the source driver:

Manually tune the source driver frequency from 75 to 82.5 GHz while watching for 4/3 harmonic responses (100-110 GHz) that are higher than the display line (<20 dBc) on the HP 8566B display.

Signal Identification

6. If a multiplier harmonic signal is found, verify whether or not it is a true in band-signal by using the spectrum analyzer's signal identification feature. This is performed as follows:

Set the frequency span to 50 MHz. Set the resolution BW to 300 kHz.

7. Tune the signal under observation to center screen on the HP 8566B display.
8. Press **[SHIFT] [FREE RUN]**.
9. If the signal is a false response, the annotation **IDENTIFIED OUT OF BAND** will appear on the display.
10. Ensure that all multiplier harmonic signals observed are within the specified level of > 20 dBc.

Measurement Uncertainty

Measurement uncertainty within the test configuration will affect the accuracy of this performance test. To obtain optimum accuracy, amplitude calibrate the spectrum analyzer by entering the conversion loss at each frequency signal under observation as explained under **Amplitude Calibration of the HP 8566B**.

Other Spurious Signals

Other signals may appear on the spectrum analyzer display in addition to the 4/3 harmonic responses. Although there are several ways to look at these signals to determine if any are out of specification, checking spurious signals without an automated procedure is very tedious. The following method is acceptable for checking spurious signals.

Increase the frequency span to approximately 20 GHz.

1. On the source driver:

Manually tune the source driver frequency from 75.0 to 110.0 GHz (in 2 GHz steps) while watching for spurious responses that are higher than the display line (<20 dBc) on the HP 8566B display.

2. Perform a signal identification (as discussed above) on any spurious signals that are above the display line.

Refer to "Troubleshooting" if you find any spurious signals out of specification.

Table 3-4. Customer Performance Test Record

HP 83558A Millimeter-Wave Source Module Serial Number _____ Date _____ Humidity* _____ Tested By _____ *(Optional) _____ Temperature* _____				
Specification Tested Limits	Lower Limit	Measured Value	Upper Limit	Measurement Uncertainties
Maximum Leveled Power 75.0 to 110.0 GHz	+0 dBm	_____		1.4 dB ⁴
Power Level Flatness¹ 75.0 to 110.0 GHz, Displayed Power +0 dBm		_____	3 dB p-p ²	2.3 dB ⁴
Power Level Accuracy³		Min/Max		
Displayed Power +0 dBm	≥ -2.0 dBm	_____/____	≤ +2.0 dBm	1.4 dB ⁴
Displayed Power -3 dBm	≥ -5.0 dBm	_____/____	≤ -1.0 dBm	1.4 dB ⁴
Displayed Power -5 dBm	≥ -7.00 dBm	_____/____	< -3.0 dBm	1.4 dB ⁴
Output SWR		_____	≤ 2.0	0.15
Multiplier Harmonic Test 75.0 to 82.5 GHz	≥ 20 dBc	_____		7.4 dB
Harmonic Spurious Test 75.0 to 110.0 GHz	≥ 20 dBc	_____		7.4 dB

1. Must have 0.5 V/GHz modification.
2. 4 dB p-p for all sources except HP 8360 series.
3. Add ±0.5 dB to the minimum and maximum values for all sources except the HP 8360 series.
4. Includes an assumed 15% calibration accuracy uncertainty for the power sensor (this value is unspecified by the power sensor manufacturer).

Measurement uncertainties listed in the table above, "Customer Performance Test Record," indicate the uncertainties which can be expected with the test set-ups given in the previous procedures, without additional error compensation.

Smaller measurement uncertainties can be achieved if additional calibrations are made to compensate for uncertainties introduced by mismatches with the power meter, sensor, couplers, spectrum analyzer and mixers. Exact numbers cannot be given here since these numbers depend on the specific calibrations made within the test system. Factory measurement uncertainties are on the order of 0.5 to 4 dB lower than those listed in the table above.

SERVICE

INTRODUCTION

This section provides instructions for troubleshooting the HP 83558A. It begins with the theory of operation followed by brief troubleshooting instructions, a block diagram, and a list of user replaceable parts with instructions for ordering parts.

The HP 83558A mm-wave source module is factory repairable only. Replaceable parts and assemblies are listed in Figures 3-10 through 3-15.

For your convenience, blue repair tags are provided for source modules being returned to Hewlett-Packard for repair. These tags are located at the end of the Systems General Information section.

SAFETY CONSIDERATIONS

The voltages present in the HP 83558A are not in the range to warrant more than normal caution, but troubleshooting and repair should be performed only by qualified personnel.



SUSCEPTIBLE TO DAMAGE FROM STATIC DISCHARGE

The best method of preventing ESD is for the technician to wear a grounding strap connected to a conductive bench mat that provides a path to ground of between 1 and 2.5 Megohms.

SERVICE PROCEDURE

Because of the interaction between the microcircuits and bias boards in the HP 83558A, the source modules must be returned to the factory for repair and/or calibration.

ADJUSTMENTS

The adjustments required in the HP 83558A after an assembly has been replaced should be performed by trained factory personnel only. Therefore, no adjustment procedures are given at this time. All repairs and/or calibrations are performed at the factory.

THEORY OF OPERATION

Introduction

The HP 83558A source module, configured with an applicable RF source driver, covers the W-band frequency range of 75.0 to 110.0 GHz with up to +0 dBm of leveled output power. In addition to system leveling (source module coupler/detector), power meters can be used to level the RF power.

The HP 83558A source module is divided into three major electrical assemblies (refer to Figure 3-9, Source Module Block Diagram, and associated mechanical hardware).

- A2 R-Band Amplifier/Doubler Assembly
- A4 W-Band Amplifier/Tripler Assembly
- A6 Coupler/Detector Assembly

The HP 83558A power supplies, bias control, and digital control signals are provided by the RF source driver and routed through the source module interface cable. Since the HP 83558A source module does not have a motherboard for interconnections, signals are routed through the instrument by ribbon cables between the interface, multiplier, and amplifier assemblies.

A block level description of the three major assemblies and their bias boards, plus the interface assembly and the power supplies, is given below. Refer to the source module block diagram, Figure 3-9, for more information.

A2 R-Band Amplifier/Doubler Assembly and Related Biases

An RF signal from a source driver is applied to the HP 83558A source module through an external cable and the Type-N input connector J1. The 12.5 to 18.33 GHz RF signal enters the amplifier at approximately 15 dBm. The signal travels through a Monolithic Microwave Integrated Circuit (MMIC) amplifier where it receives approximately 7 dB of gain. The MMIC amplifier is biased by the A1 R-Bias/Logger Assembly.

The signal is then passed to the R-Band multiplier where the first doubling takes place. The signal is doubled by two matched pair diodes which distort the input signal. Diode biasing is also provided by the A1 R-Bias/Logger Assembly. Upon distortion, various output signals are generated as harmonics of the original input signal.

The output signal is then coupled from the R-Band Amplifier/Doubler Assembly to the W-Band Amplifier/Tripler Assembly through 2.4 mm connectors.

A4 W-Band Amplifier/Tripler Assembly and Related Biases

The 25 to 36.66 GHz RF signal from the R-Band Amplifier/Doubler assembly is coupled to the W-Band Amplifier/Tripler Assembly where a second amplification and multiplication takes place.

The signal passes through an eight FET amplifier which provides approximately 14 dB of gain to the RF signal. Half of the FET amplifiers are biased from a +5V regulator circuit on the A3 W-Band Bias Assembly, and the other half are biased from a +5V regulator circuit on the A5 Digital Interface Assembly.

After leaving the millimeter amplifier, the 25 to 36.66 GHz signal enters a W-Band multiplier where the second multiplication takes place. The signal is tripled by two matched pair diodes which distort the input signal. Diode biasing takes place on the A3 W-Band Bias Assembly. Upon distortion, various output signals are generated as harmonics of the original input signal.

After harmonic generation (multiplication), the RF signal is coupled through a waveguide conversion section. The output waveguide acts as a high pass filter before sending the signal to the Coupler/Detector Assembly.

A6 Coupler/Detector Assembly and Related Biases

For leveled output power across the frequency sweep, an external 10 dB directional coupler directs a portion of the RF signal to a detector. The detector produces a voltage proportional to the sampled RF signal. This voltage is passed to the A1 R-Bias/Logger where it is applied to the log amplifier circuitry.

The DET voltage from the A6 assembly is buffered and sent to the single slope log amplifier. The log amplifier converts the linear detector voltage into a DC voltage as a log function of power level. This voltage is also applied to a high impedance amplifier as control signal EXT LEV. Since the detector does not have the same response over the entire frequency range, the detector flatness compensation from the A5 interface assembly is summed with the log amplifier output prior to the last output buffer. The logged and compensated EXT LEV signal is routed to the center coaxial pin on the source module interface cable for routing to the EXT ALC input of the source driver.

A5 Interface Assembly

The interface assembly contains two major sections, analog and digital control. Within the analog section the gate and drain supplies for the W-Band Amplifier are provided. The flatness compensation and gate control circuitry are referenced to the 0.5 V/GHz frequency reference provided by the source driver.

The digital control section contains digital address and data line buffers, decoding and counting circuitry. The NOVRAM (non volatile, random access memory), a RAM-ROM (random access memory-read only memory) combination device, contains digital information (frequency, power and ALC information) when used with the HP 83550A RF plug-in, and digital error corrected leveling flatness values when used with the HP 8360-Series synthesizers.

Precision ± 10 V supplies (generated from +15V in the source driver) are routed through the ribbon cable from the interface assembly to all other assemblies, and are also used by the analog circuitry on the interface board.

Power Supplies

Power supplies for source module operation are provided by the source driver and routed through the source module interface cable assembly. Power supplies are connected to the interface assembly and used by all three major assemblies. The +10 VDC and -10 VDC supplies are used for local analog application where regulation and current control are critical. The +5 VDC is used only for the interface assembly digital circuitry. The digital and analog grounds are separate to prevent noise problems.

TROUBLESHOOTING

Introduction

This section contains instructions for troubleshooting the HP 83558A mm-wave source module.

Before troubleshooting the source module independently, ensure that the failure of system specifications (various source system configurations) is caused by the source module. System operator's checks and system troubleshooting procedures are outlined in all Source System Guides. Determination of the specific failed system instrument is necessary prior to individual instrument troubleshooting.

Begin troubleshooting by checking all system connections. If the problem remains, perform the Maximum Levelled Power test earlier in this section to isolate the source module. If the source module does not pass this test, check the power out of the source (it should be approximately +17 dBm). If the source output power is correct and the source module fails to meet its specification, return the unit to the nearest HP service center for repair.

Refer to the theory of operation and block diagram for reference throughout the troubleshooting procedures.

If Your Instrument Fails

If your source module fails to meet its published specification, repackage it according to the instructions given in the System General Information section (in paragraphs titled Shipments and Returning For Service). Then send the unit to the nearest HP service center.

Operational Checks

Several system operational problems may be encountered if attention is not paid to the system instruments setup (cabling, etc.). A few checks for locating operation problems in a source system configuration which includes an HP 8349B follows:

1. If the source module output power, as indicated on a power meter, is approximately 3 dB higher than the HP 8349B output display level, the most likely cause is that the 0.5V/GHz connection is not present.

The 0.5V/GHz signal supplies the varactor filter tracking and flatness compensation circuitry with a frequency reference that affects the source module output power and flatness characteristics.

2. If the system has leveling or RF power problems, the RF input cable may be the cause of this problem. The RF cable is typically specified over the frequency range of 8 to 20 GHz with a 2 to 3 dB loss. Characterization of the cable with a network analyzer may be necessary to eliminate it from any system problems encountered. If the cable has large power drops, or measures significantly different from the typical value, it should be replaced.
3. The source module input SWR should be checked in case of ALC leveling problems. A source module input connector or cable failure could lead to leveling problems. If the input SWR is appreciably larger than the typical value of 7:1, the source module should be returned for repair.

HP83558A W-BAND MILLIMETER-SOURCE MODULE BLOCK DIAGRAM

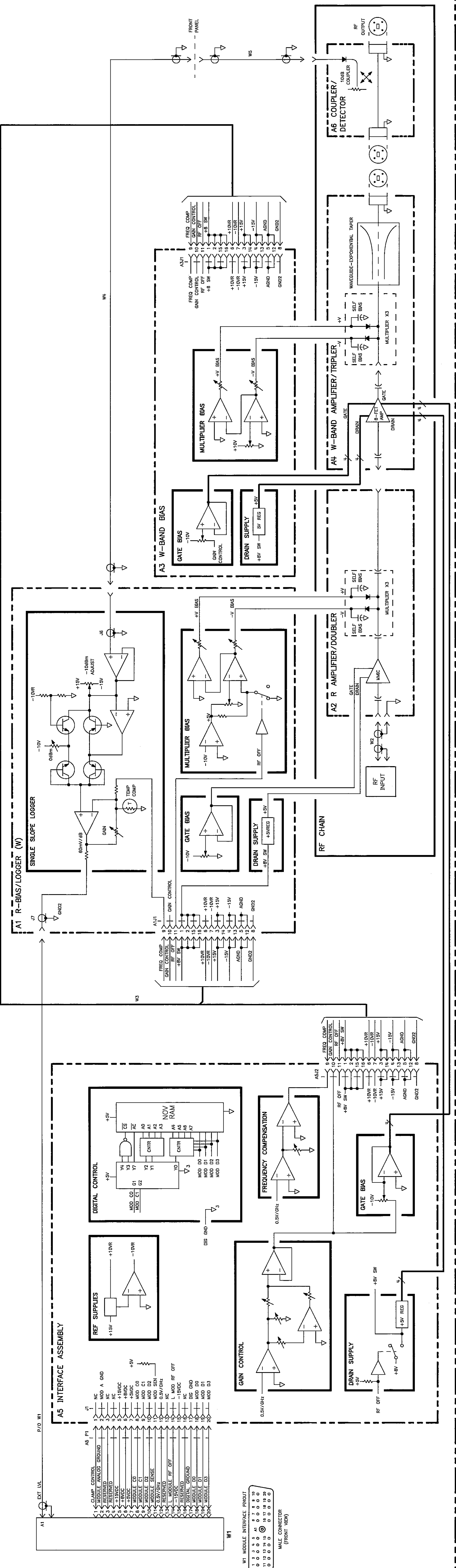

Figure 3-9. HP 83558A Overall Block Diagram
Specifications and Service 3-25/3-26
HP 83558A

REPLACEABLE PARTS

Introduction

This section contains information for ordering parts. Figures 3-10 through 3-15 list the customer replaceable parts for the HP 83558A. Table 3-3 lists abbreviations used in the parts list.

Replaceable Parts List

Figures 3-10 through 3-15 provide the locations and lists of replaceable parts.

The information given for each part consists of the following:

- a. The Hewlett-Packard part number.
- b. The total quantity (Qty) in the figure.
- c. The description of the part.

Ordering Information

To order a part listed in the Replaceable Parts List, quote the Hewlett-Packard part number, indicate the quantity, and address the order to the nearest Hewlett-Packard Office.

Table 3-3. Reference Designations, and Abbreviations

Reference Designators			
A	Assembly	Q	Transistor
C	Capacitor	R	Resistor
CR	Diode	S	Switch
J	Electrical Connector (Stationary Portion), Jack	TP	Test Point
L	Coil, Inductor	U	Integrated Circuit, Microcircuit
MP	Miscellaneous Mechanical Part	W	Cable, Transmission Path, Wire
P	Electrical Connector (Movable Portion), Plug	X	Socket

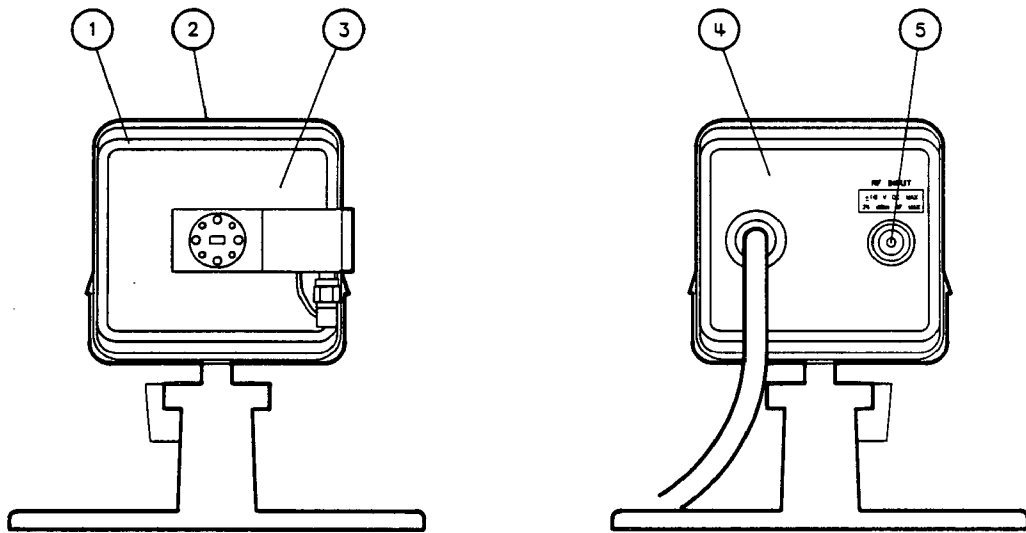

Item	Ref. Desig.	HP Part Number	Qty.	Description
1	J1	83556-20001	2	Housing-painted
2		83556-40001	2	Bumper 86×86 MM
3		83558-00001	1	Panel-Front
4		83556-00002	1	Panel-Rear
5		86290-60005	1	Connector Assembly Type-N
Not Shown		0515-1336	5	Exterior Screws 8 mm
Not Shown	83558-80003	1	Label in HP Part No. 83558A	

Figure 3-10. Front and Rear Views, Parts Identification

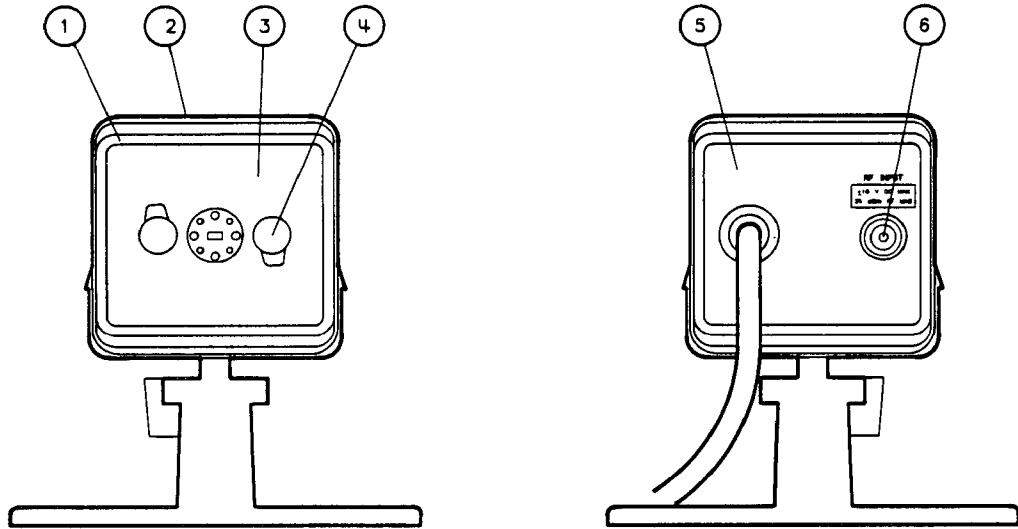

Item	Ref. Desig.	HP Part Number	Qty.	Description
1	J1	83556-20001	2	Housing-painted
2		83556-40001	2	Bumper 86×86 MM
3		85100-00001	1	Panel-Front
4		83556-20002	2	Waveguide Clamp
5		83556-00002	1	Panel-Rear
6		86290-60005	1	Connector Assembly Type-N
Not Shown		0515-1336	6	Exterior Screws 8 mm
Not Shown		83558-80003	1	Label in HP Part No. 83558A

Figure 3-11. Option 001 Front and Rear Views, Parts Identification

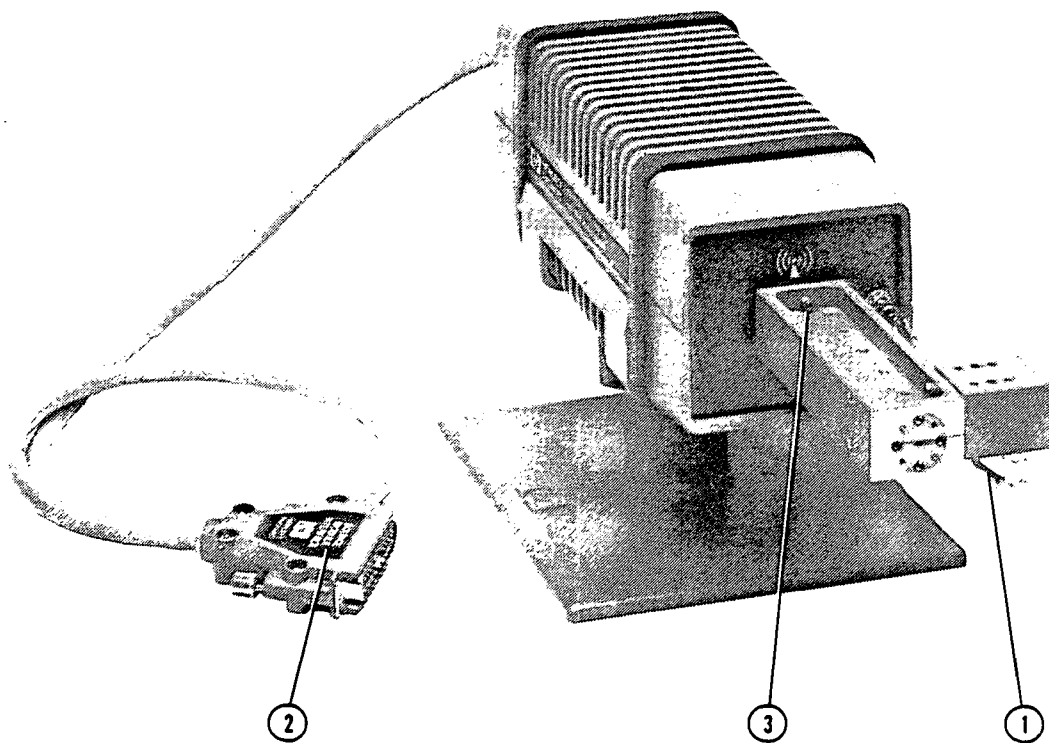

Item	Ref. Desig.	HP Part Number	Qty.	Description
1	W1	83557-60005	1	Cable - ALC External Level
2		83556-60001	1	Source Module Interface Cable
		1390-0431	2	Captive Screws
		0624-0098	4	Screws attached to shell
		83556-80006	1	Label-Mod Interface
		0535-0992	1	Nut 10 mm
		2190-0684		Washer
		2950-0132	1	Nut
		2190-0104	1	Washer
3		1390-0671	4	Captive Screws

Figure 3-12. Top View, Assemblies and Parts Identification

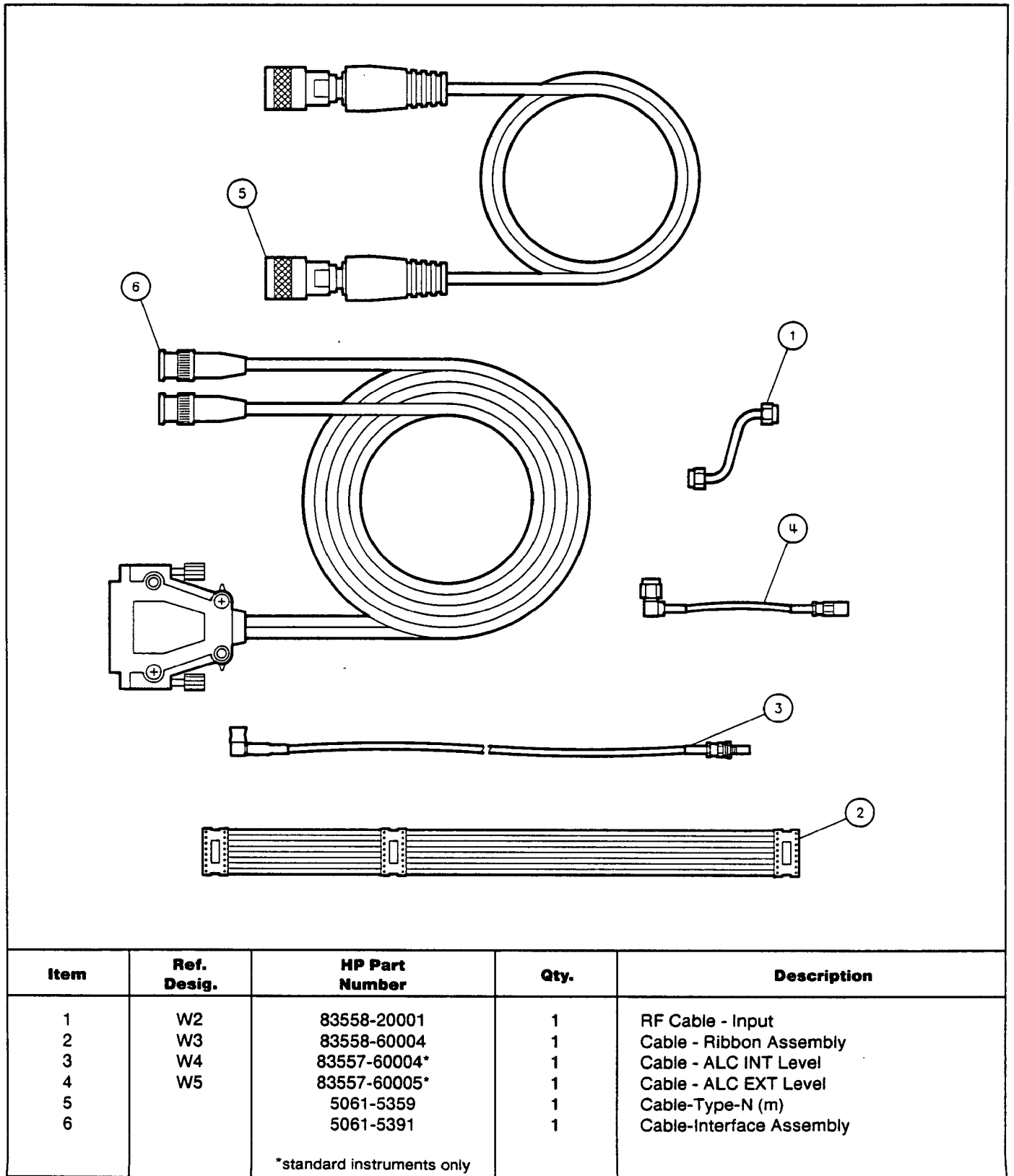
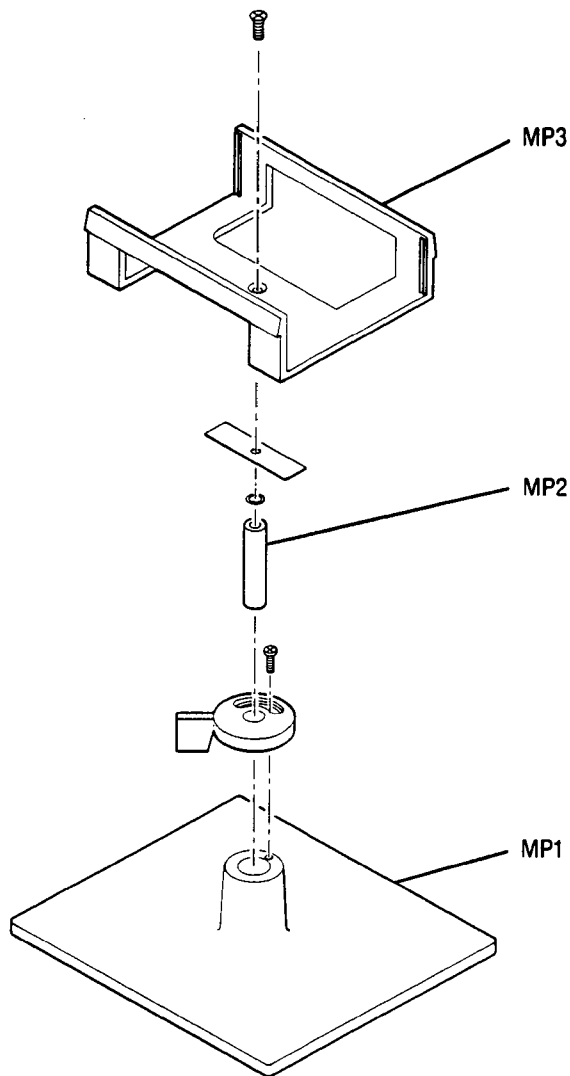
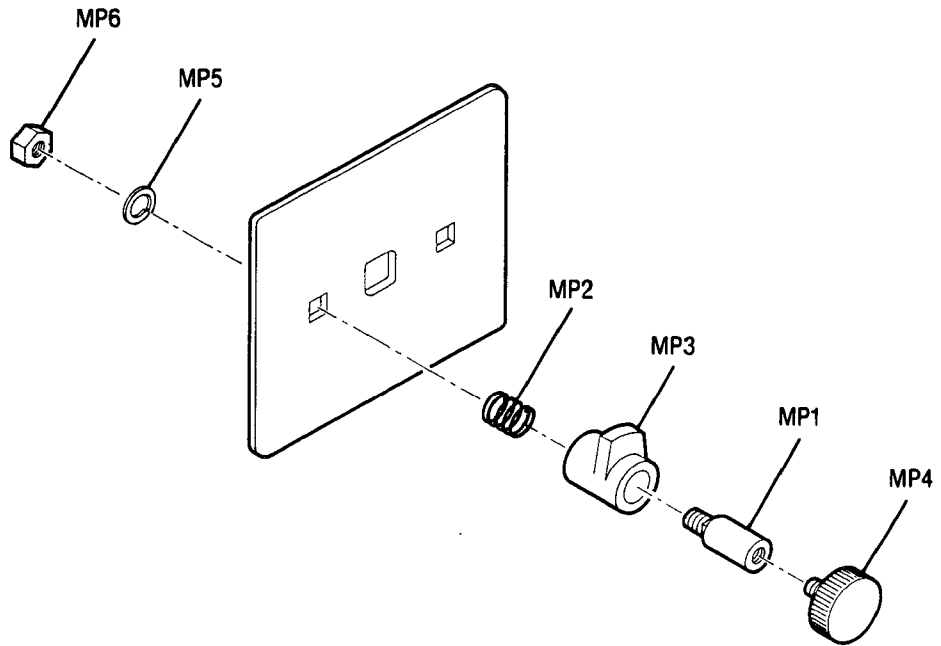

Figure 3-13. RF Cables Identification



Item	HP Part Number	Description
MP1	83556-60010 83556-20017 0515-0897	MM Stand and Cradle Assembly (complete) Base Casting Screw M 3×0.5
MP2	0403-0423 83556-20018 0515-1129	Anti-skid Pads ROD SS-60.0 mm long Screw M 4×0.7
MP3	2190-0599 83556-40002 83556-40003	Lock Washer Cradle Washer Rec

Figure 3-14. Source Module Stand, Exploded View



Item	HP Part Number	Qty.	Description
MP1	83556-20003	2	Stud Center
MP2	1460-0019	4	Spring CPR
MP3	83556-20002	2	Wing Clamp
MP4	83556-20004	2	Clamp Screw
MP5	2190-0587	2	Lock Washer
MP6	0535-0005	2	Nut

Figure 3-15. Waveguide Connection Clamps, Exploded View (Option 001 only)